





























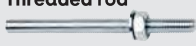















Chemical Fastening Systems

ResiFIX		152
SH		172
SH-1000		172
IGH		172
Resi AST		173
ResiTHERM		175
VA		183
VA AST		185

Fastening Injection System

ResiFIX

ResiFIX Systems in Comparison

	ResiFIX VYSF				ResiFIX VY ECO SF	ResiFIX PYSF				ResiFIX Pure Epoxy	
	300	345	410	300	300	165	300	345	410	385	585
Content [ml]	280ml	345 ml	410 ml	300 ml	300 ml	165 ml	300 ml	345 ml	410 ml	385	585
Nozzles included	 2	 2	 1	 2	 2	 2	 1	 1	 1	 1	 1
Types	Standard			Cool	Standard	Standard			Standard		
Shelf life*	18 months			12 mon.	12 months	12 months	18 months		24 months		
A4 STAINLESS STEEL Threaded rod				steel 4.6, 5.8, 8.8 stainless steel	steel 4.6, 5.8, 8.8 stainless steel	steel 4.6, 5.8, 8.8 stainless steel			steel 4.6, 5.8, 8.8 stainless steel		
Reinforcing bars				✓	✓ (only Option 7)	✗			✓		
Option 1 Approval for cracked concrete (Option 1)	 M8 - M30, Ø8 - Ø32			 M8 - M16				 M8 - M30, Ø8 - Ø32			
Option 7 Approval for non-cracked concrete (Option 7)	 M8 - M30, Ø8 - Ø32			 M8 - M24, Ø8 - Ø25	 M8 - M16			 M8 - M30, Ø8 - Ø32			
Rebar Approval for post-installed rebar connections	 Ø8 - Ø32			✗		✗			 Ø8 - Ø25		
Masonry Approval for masonry	 M8 - M16			 M8 - M16		 M8 - M16			✗		
R 120 Fire test certification (R 120)				✗		✗					
FIXING seismic Usage under seismic action						✗					
LEED tested EMISSIONS DANS L'AIR INTERIEUR A+ Emissions in closed spaces	✓			✓		✓			✓		
STYRENE FREE Styrene free	✓			✓		✓			✓		
Performance in non-cracked concrete C20/25 (M10-90)											
Performance in hollow brick HLz 12 (M10-130)									✗		
Wet drill holes	✓			✓		✓			✓		
Waterfilled drill holes	✓			✓		✓			✓		
Suitable for contact with drinking water	✓			✗		✗			✓		
Min. temperature of concrete	≥ -10°C		≥ -20°C	≥ -5°C		≥ -5°C			≥ +5°C		
Temperature range after curing	-40°C to +120°C			-40°C to +80°C		-40°C to +80°C			-40°C to +72°C		
Chemical resistance	very high			high		high			excellent		
Odour	marginal			medium		medium			marginal		

Risk of staining in natural stone! Before use, we recommend a 5-days test (there is no risk with Pure Epoxy BRSF).
*All cartridges can be used until the expiration date by resealing with the cap or by replacing the static mixer.

Fastening injection system

ResiFIX



Advantages



Injection mortar ResiFIX VYSF (styrene free)



Injection mortar ResiFIX VY ECO SF (styrene free)



Injection mortar ResiFIX PYSF (styrene free)



Injection mortar ResiFIX Pure Epoxy (styrene free)

Approvals and certificates



European Technical Assessment
Option 1 for cracked concrete



see assessment



European Technical Assessment
for masonry



Suitable building materials

Very suitable



- Concrete
- Solid brick
- Solid sand-lime brick
- Lightweight solid concrete blocks
- Aerated concrete



- Hollow brick
- Hollow sand-lime brick
- Lightweight hollow concrete blocks
- Natural stone (risk of discolouration)



Typical applications

- Steel constructions
- Cantilevers
- Facade substructures
- Machines
- Guard rails
- Canopies
- Distance mountings
- Door and window frames
- Stairways
- Wood constructions
- Cable trays
- Pipe installations

Fastening injection system ResiFIX

Mounting in concrete and solid brick

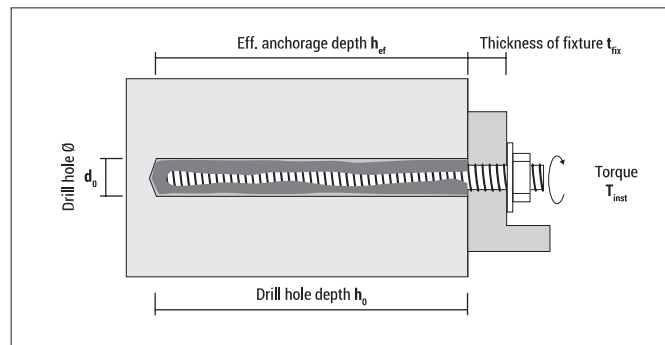
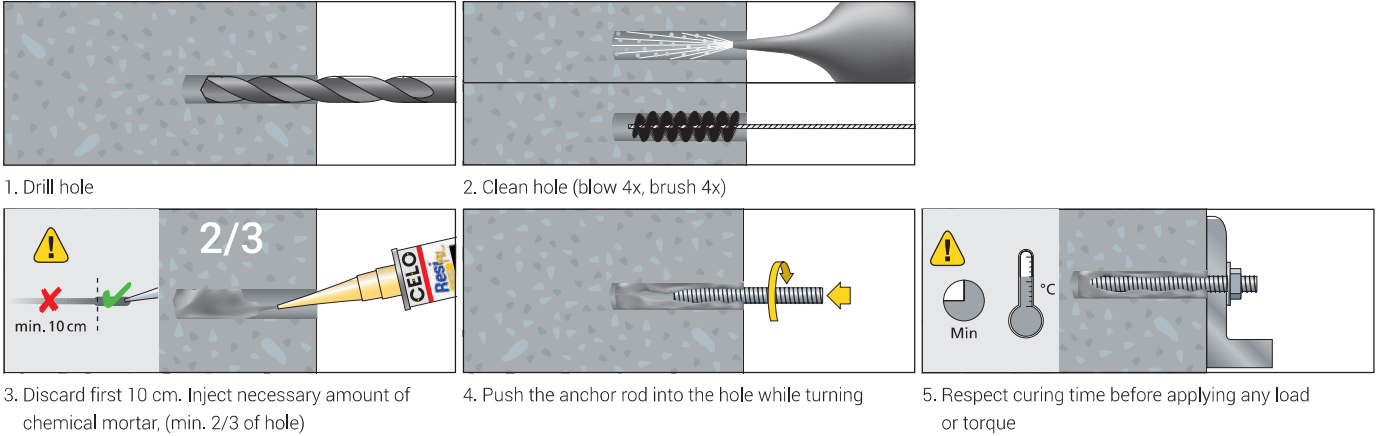

Mounting in hollow brick

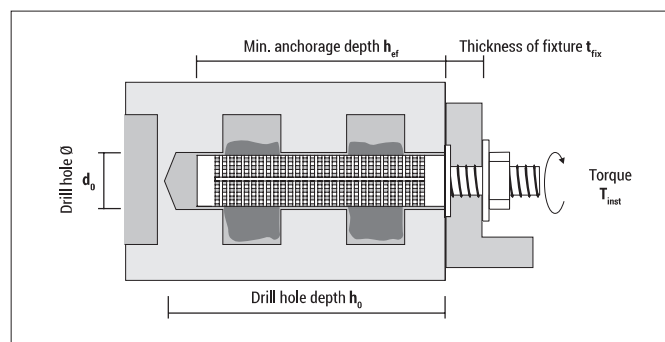
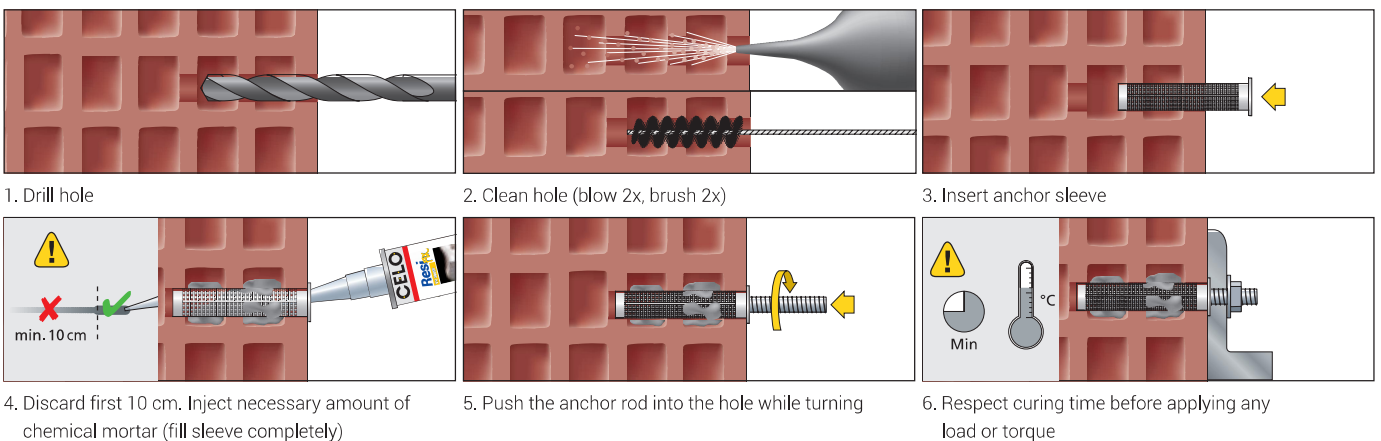

Fastening injection system ResiFIX

Estimation of needed volume [all types]

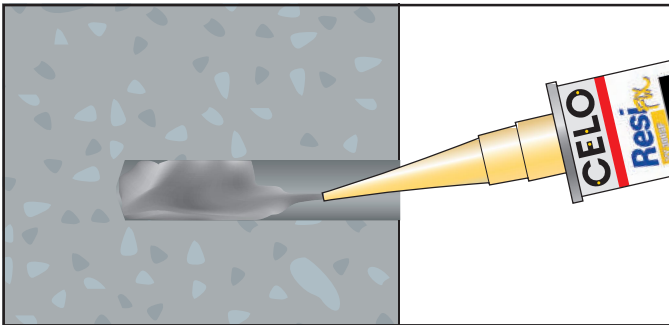

Consumption in solid materials Calculation method: Complete filling of the drill hole*

Anchor stud RAST or VA AST	d ₀ [mm]	Drill hole h _{ef, Stand} ¹⁾ [mm]	Volume [cm ³ =ml]	Number of fixings per ResiFIX cartridge				
				165 ml [fixings]	280 ml [fixings]	300 ml [fixings]	345 ml [fixings]	410 ml [fixings]
M8	10	80	6,3	26,3	44,6	47,8	54,9	65,3
M10	12	90	10,2	16,2	27,5	29,5	33,9	40,3
M12	14	110	17,0	9,7	16,5	17,7	20,4	24,2
M16	18	125	31,8	5,2	8,8	9,4	10,9	12,9
M20	24	170	76,9	2,1	3,6	3,9	4,5	5,3
M24	28	210	129,2	1,3	2,2	2,3	2,7	3,2
M30	35	280	269,3	0,6	1,0	1,1	1,3	1,5

* According to the ETA assessment only 2/3 of the drill hole has to be filled with mortar. The experience shows that the user uses more, so that the filling of the complete drill hole is calculated here.

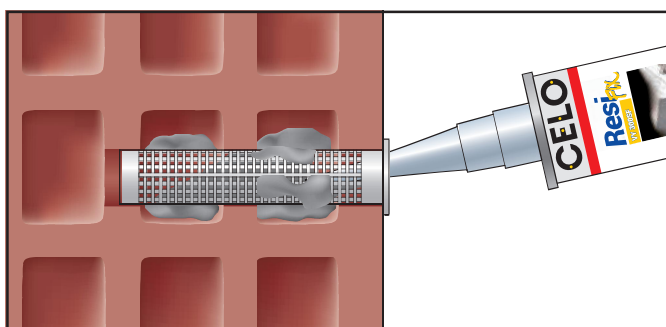

Consumption in hollow bricks with sleeve Calculation method: Complete filling of the sleeve + 15%

Sleeve	Anchor stud RAST or VA AST	d ₀ [mm]	Drill hole h ₀ [mm]	Volume [cm ³ =ml]	Number of fixings per ResiFIX cartridge				
					165 ml [fixings]	280 ml [fixings]	300 ml [fixings]	345 ml [fixings]	410 ml [fixings]
SH 12/80	M6 / M8	12	85	9,1	15,9	26,9	28,8	33,2	39,4
SH 16/85	M8 / M10	16	90	17,1	8,4	14,3	15,3	17,6	20,9
SH 16/130	M8 / M10	16	135	26,1	5,5	9,3	10,0	11,5	13,6
SH 20/85	M12 / M16	20	90	26,7	5,4	9,1	9,8	11,2	13,4
SH 20/130	M12 / M16	20	135	40,8	3,5	6,0	6,4	7,3	8,7
SH 20/200	M12 / M16	20	205	62,8	2,3	3,9	4,2	4,8	5,7

Fastening injection system

ResiFIX VYSF



Approvals and certificates



European Technical Assessment
Option 1 for cracked concrete
(M8 - M30, Ø8 - Ø32)



European Technical Assessment
for masonry
(M8 - M16)



European Technical Assessment
for post-installed rebar
connections (Ø8 - Ø32)



Approved for anchor rods and reinforced steel bars

- **Various applications**



Class A+: Lowest emissions of critical substances in closed spaces

- **Harmless to health after curing**



Sustainability certification LEED

- **Environmentally friendly, low-pollutant, low-emission and sustainable construction product**



Usage under seismic conditions

- **Tested for use in areas with high risk of earthquakes**



European Technical Assessment Option 1 for cracked and non-cracked concrete (M8 - M30)

- **For a wide range of safety critical applications**



Apart from the 410 ml cartridge, two mixing nozzles are included

- **You can continue working immediately after an interruption**



1350 kg
M10-90mm
C20/25

Very high load values

- **Heavy-duty usage**



Waterfilled
drill holes

Usage also in water-filled drill holes and suitable for contact with drinking water

- **Extended range of applications**



R 120
see assessment

Fire resistance test R120

- **Fulfills fire protection requirements**



Masonry
(M8 - M16)

European Technical Assessment for masonry (M8 - M16)

- **For more application flexibility**



Styrene free

- **Reduced odour exposure**

Fastening injection system ResiFIX VYSF

Vynylester VYSF [styrene free]

Type	Art-No	Content [ml]	Mixings nozzles included [pcs]	Shelf life [months]		€/pc	[pcs]
VY 300 SF	300VSF	280	2	18	●		12
VY 345 SF	345VSF	345	2	18	●		12
VY 410 SF	410VYSF	410	1	18	●		12

Vynylester VYSF Cool [styrene free]

for -20°C to +10°C



Type	Art-No	Content [ml]	Mixings nozzles included [pcs]	Shelf life [months]		€/pc	[pcs]
VY 300 SF Cool	300VCSF	300	2	12	●		12

Seasonal article



30 x 40 x 23 cm

Universal box with ResiFIX VY 300 SF, VY 345 SF

Type	Art-No	Content [cartridges]	Mixings nozzles included [pcs]	Shelf life [months]		€/box	[pcs]
VY 300 SF in universal box	SYS300VSF20	20	40	18	●		1
VY 345 SF in universal box	SYS345VSF20	20	40	18	●		1

Curing times ResiFIX Vynylester VYSF

Temperature of building material	[°C]	> -10 ¹⁾	> -5	> 0	> +5	> +10	> +20	> +30	> +40
Max. working time	[min]	90	90	45	25	15	6	4	1,5
Min. curing time ²⁾	[min]	24h	14h	7h	2h	80	45	25	15

¹⁾ Cartridge temperature min. 15 °C

²⁾ Double curing time in wet concrete

Curing times ResiFIX Vynylester VYSF Cool

Temperature of building material	[°C]	> -20	> -15	> -10	> -5	> 0	> +5	+10	> +10
Max. working time	[min]	75	55	35	20	10	6	6	
Min. curing time ¹⁾	[min]	24h	16h	10h	5h	2,5h	80	60	

¹⁾ Double curing time in wet concrete

Fastening injection system ResiFIX VYSF



Fastening in concrete (Standard and Cool)

Permissible loads F_{per} in [kN] in non-cracked concrete C20/25 (Option 7) and cracked concrete C20/25 (Option 1) without influence of spacing and edge distance, installation parameters and unit dimensions. Total safety factors as per ETAG 001 included (γ_M and γ_p). Design according to TR029. See ETA assessment for design and calculations.

Anchor studs RESI AST, VA AST	M8	M10	M12	M16	M20	M24	M 27	M30
Drill hole \varnothing d_0 [mm]	10	12	14	18	24	28	30	35
Anchorage depth $h_{ef,min} / h_{ef,stand} / h_{ef,max}$ [mm]	60 / 80 / 160	60 / 90 / 200	70 / 110 / 240	80 / 125 / 320	90 / 170 / 400	96 / 210 / 480	108 / 240 / 540	120 / 280 / 600

Permissible tension load ¹⁾²⁾ [24 °C / 40 °C] ³⁾ in non-cracked concrete (dry or wet)

Zinc plated 5.8	N_{per} [kN]	7,2/8,7/8,7	9,0/13,5/13,8	11,7/19,7/20,0	14,3/28,0/37,3	17,1/44,4/58,3	18,8/61,0/83,9	23,1/74,5/109,4	26,3/93,9/133,5
Stainless steel A4	N_{per} [kN]	7,2/9,6/9,8	9,0/13,5/15,5	11,7/19,7/22,5	14,3/28,0/41,9	17,1/44,4/65,5	18,8/61,0/94,3	23,1/57,3/57,4	26,3/70,0/70,0

Permissible tension load ¹⁾²⁾ [24 °C / 40 °C] ³⁾ in cracked concrete (dry or wet)

Zinc plated 5.8	N_{per} [kN]	2,9/3,8/7,7	3,7/5,6/12,5	5,8/9,1/19,7	8,8/13,7/35,1	12,2/23,3/54,9	13,4/34,6/79,0	16,5/52,5/109,4	18,8/66,9/133,5
Stainless steel A4	N_{per} [kN]	2,9/3,8/7,7	3,7/5,6/12,5	5,8/9,1/19,7	8,8/13,7/35,1	12,2/23,3/54,9	13,4/34,6/79,0	16,5/52,5/57,4	18,8/66,9/70,0

Permissible tension load ¹⁾²⁾ [50 °C / 80 °C] ³⁾ in non-cracked concrete (dry or wet)

Zinc plated 5.8	N_{per} [kN]	5,4/7,2/8,7	6,7/10,1/13,8	9,4/14,8/20,0	14,3/22,4/37,3	17,1/38,1/58,3	18,8/53,4/83,9	23,1/60,6/109,4	26,3/68,1/133,5
Stainless steel A4	N_{per} [kN]	5,4/7,2/9,8	6,7/10,1/15,5	9,4/14,8/22,5	14,3/22,4/41,9	17,1/38,1/65,5	18,8/53,4/94,3	23,1/57,4/57,4	26,3/68,1/70,0

Permissible tension load ¹⁾²⁾ [50 °C / 80 °C] ³⁾ in cracked concrete (dry or wet)

Zinc plated 5.8	N_{per} [kN]	1,8/2,4/4,8	2,6/3,9/8,7	4,2/6,6/14,4	6,4/10,0/25,5	9,0/17,0/39,9	11,5/25,1/57,4	16,5/36,4/78,8	18,8/47,1/101,0
Stainless steel A4	N_{per} [kN]	1,8/2,4/4,8	2,6/3,9/8,7	4,2/6,6/14,4	6,4/10,0/25,5	9,0/17,0/39,9	11,5/25,1/57,4	16,5/36,4/57,4	18,8/47,1/70,0

Permissible shear load ¹⁾ in non-cracked concrete

Zinc plated 5.8	V_{per} [kN]	5,2	8,3	12,0	22,4	35,0	45,2/50,4/50,4	55,5/65,6/65,6	63,2/80,1/80,1
Stainless steel A4	V_{per} [kN]	5,9	9,3	13,5	25,1	39,2	45,2/56,5/56,5	34,5/34,5/34,5	42,1/42,1/42,1

Permissible shear load ¹⁾ in cracked concrete

Zinc plated 5.8	V_{per} [kN]	5,2/5,2/5,2	8,3	12,0	21,1/22,4/22,4	29,3/35,0/35,0	32,2/50,4/50,4	39,6/65,6/65,6	45,1/80,1/80,1
Stainless steel A4	V_{per} [kN]	5,7/5,9/5,9	9,0/9,3/9,3	13,5	21,1/25,1/25,1	29,3/39,2/39,2	32,2/56,5/56,5	34,5/34,5/34,5	42,1/42,1/42,1

Permissible bending moment (Zinc plated 5.8)	M_{per} [Nm]	10,7	21,4	37,4	94,9	185,2	320,0	476,2	642,1
Permissible bending moment (Stainless steel A4)	M_{per} [Nm]	12,0	24,0	41,9	106,4	207,8	359,0	250,1	337,2

Spacing and edge distance

Spacing	$S_{cr,N}$ [mm]	180/240/480	180/270/600	210/330/720	240/375/960	270/510/1200	288/630/1440	324/720/1620	360/840/1800
Edge distance	$c_{cr,N}$ [mm]	90/120/240	90/135/300	105/165/360	120/188/480	135/255/600	144/315/720	162/360/810	180/420/900
Minimum spacing	S_{min} [mm]	40	50	60	80	100	120	135	150
Minimum edge distance	c_{min} [mm]	40	50	60	80	100	120	135	150
Min. thickness of structural part	h_{min} [mm]	$h_{ef} + 30 \text{ mm} \geq 100 \text{ mm}$				$h_{ef} + 2d_0$			
Max. installation torque	$T_{inst} \leq$ [Nm]	10	20	40	80	120	160	180	200

¹⁾ Values are valid for $h_{ef,min} / h_{ef,stand} / h_{ef,max}$

²⁾ For higher concrete strengths up to C50/60 the values increase by max. 10%.

³⁾ Max. long term temperature / max. short term temperature after installation. For temperature range 72°C/120°C please see ETA assessment

If underrun the char. spacing or edge distance (C_{cr} or S_{cr}) the loads must be reduced. h_{min} , S_{min} and C_{min} must be observed.

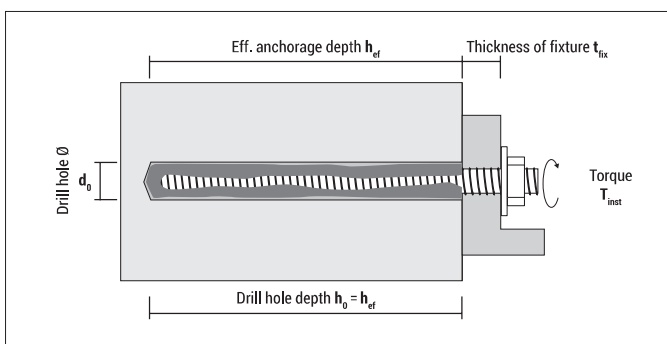

Fastening injection system ResiFIX VYSF



Fastening in masonry (Solid and hollow brick) Standard and Cool

Permissible loads in [kN] and installation parameters - selection; for additional brick types and application conditions please see ETA assessment.

Suitable building materials		Density ρ [kg/dm ³]	Compressive strength f_b [N/mm ²]	Anchor studs RESI AST, VA AST Size	Sleeve Size	Min. Anchorage depth h_{ef} [mm]	Use category dry / dry 24°C/40°C ¹⁾ Tension load N_{per} [kN] Shear load V_{per} [kN]	
Solid sand-lime brick KS (NF)		≥ 2,0	≥ 20	M8	without / SH 12-80	80 / 80	1,71 / 1,57	1,14 / 1,14
				M10	without / SH 16-85	90 / 85	1,71 / 1,43	1,29 / 1,14
				M12	without / SH 20-85	100 / 85	1,71 / 1,14	1,14 / 1,14
				M16	without / SH 20-85	100 / 85	1,43 / 1,14	1,14 / 1,14
Solid brick Mz (DF)		≥ 1,6	≥ 20	M8	without / SH 12-80	80 / 80	1,29 / 1,29	1,43 / 1,43
				M10	without / SH 16-85	90 / 85	1,57 / 1,43	1,43 / 1,43
				M12	without / SH 20-85	100 / 85	1,71 / 1,43	1,43 / 1,43
				M16	without / SH 20-85	100 / 85	1,71 / 1,43	2,29 / 1,43
Aerated concrete AAC6		≥ 0,6	≥ 6	M8	without	80	0,89	2,14
				M10	without	90	1,43	3,57
				M12	without	100	1,79	3,57
				M16	without	100	2,32	3,57
Hollow sand-lime brick KSL (KSL 3DF)		≥ 1,4	≥ 12	M8	SH 12-80	80	0,57	0,86
				M10	SH 16-85	85	0,57	1,29
				M10	SH 16-130	130	0,71	1,29
				M12	SH 20-85	85	1,71	1,29
Hollow brick HLz (16DF)		≥ 0,8	≥ 12	M8	SH 12-80	80	1,00	1,14
				M10	SH 16-85	85	1,00	1,86
				M10	SH 16-130	130	1,43	1,86
				M12	SH 20-85	85	1,00	2,00
				M16	SH 20-85	85	1,00	2,00

N_{per}, V_{per} : Permissible loads incl. safety factors (γ_M and $\gamma_V = 1,4$), without influence of spacing and edge distance.

Drilling method: KS and Mz: hammer drilling; Aerated concrete, KSL and HLz: rotary drilling

¹⁾ Max. long term temperature / max. short term temperature. Long-term temperature is constant over a longer period of time. The short-term temperature is only present for a short time (day/night change).

Spacing and edge distance

Suitable building materials	Anchor stud	Sleeve	Char. Edge distance c_{cr} [mm]	Min. Edge distance c_{min} [mm]	Char. Spacing parallel to the bearing joint $s_{cr, }$ [mm]	Char. Spacing perpendicular to the bearing joint $s_{cr,\perp}$ [mm]	Min. Spacing s_{min} [mm]	Max. Torque T_{inst} [Nm]
Solid sand-lime brick KS (NF)	M8	without	120	60	240	240	120	10
	M10	without	135	60	270	270	120	20
	M12	without	150	60	300	300	120	20
	M16	without	150	60	300	300	120	20
Solid brick Mz (DF)	M8	without	120	60	240	240	120	6
	M10	without	135	60	270	270	120	10
	M12	without	150	60	300	300	120	10
Aerated concrete AAC6	M8	without	120	75*	240	240	100	2
	M10	without	135	75*	270	270	100	2
	M12	without	150	75*	300	300	100	2
Hollow sand-lime brick KSL (KSL 3DF)	M8	SH 12-80	100	60	240	120	120	8
	M10	SH 16-85	100	60	240	120	120	8
	M10	SH 16-130	100	60	240	120	120	8
	M12,M16	SH 20-85	120	60	240	120	120	8
Hollow brick HLz (16DF)	M8	SH 12-80	100	100	497	238	100	6
	M10	SH 16-85	100	100	497	238	100	6
	M10	SH 16-130	100	100	497	238	100	6
	M12,M16	SH 20-85	120	120	497	238	100	6

Permissible bending moment

Steel		Anchor stud			
		M8	M10	M12	M16
Zinc plated 5.8	M_{per} [Nm]	10,9	21,1	37,7	94,4
Stainless steel A4	M_{per} [Nm]	11,9	23,8	42,1	106,7

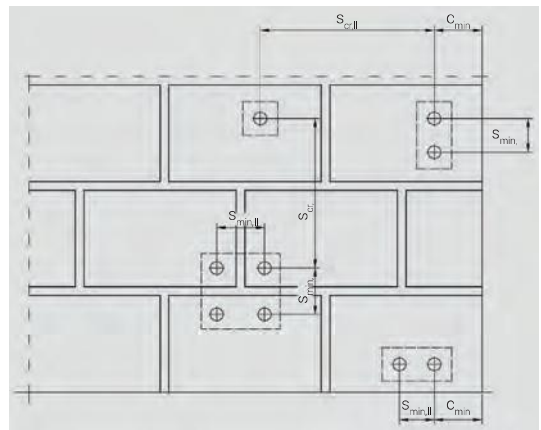

* Values are valid for pull-out load; for shear load parallel to the free edge: 75 mm, for shear load perpendicular to the free edge: $1,5 \times h_{ef}$
Group factors for anchor groups under tension, shear load parallel or perpendicular to the free edge: please see ETA assessment

Fastening injection system

ResiFIX VY

ECO SF



Approvals and certificates

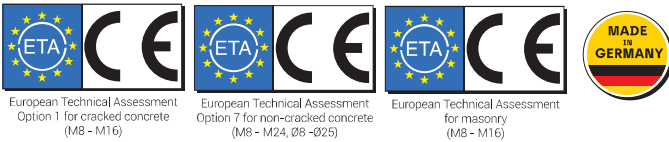

European Technical Assessment
Option 1 for cracked concrete
(M8 - M16)

European Technical Assessment
Option 7 for non-cracked concrete
(M8 - M24, Ø8 - Ø25)

European Technical Assessment
for masonry
(M8 - M16)



Class A+: Lowest emissions of critical substances in closed spaces

- Harmless to health after curing



Sustainability certification LEED

- Environmentally friendly, low-pollutant, low-emission and sustainable construction product



European Technical Assessment Option 1 for cracked (M8 - M16) and non-cracked concrete (M8 - M24)

- For a wide range of safety critical applications



Usage under seismic conditions

- Tested for use in areas with high risk of earthquakes



Two mixing nozzles are included with every cartridge

- You can continue working immediately after an interruption



Usage also in water-filled drill holes

- Extended range of applications



Good load values in concrete and masonry

- Multi-material usage

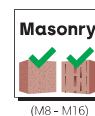

European Technical Assessment for masonry (M8 - M16)

- For more application flexibility





Styrene free

- Reduced odour exposure

Fastening injection system ResiFIX VY ECO SF



Vinylester VY ECO SF (styrene free)

Type	Art-No	Content [ml]	Mixings nozzles included [pcs]	Shelf life [months]		€ / pc	 [pcs]
VY ECO 300 SF	300VYECOSF	300	2	12	●		12

Curing times ResiFIX Vinylester VY ECO SF

Temperature of building material		> -5	> 0	> +5	> +10	> +20	> +30	> +40
Max. working time	[min]	90	45	25	20	6	4	2
Min. curing time ²⁾	[min]	6h	3h	2h	100	45	25	20

¹⁾ Cartridge temperature min. 15 °C

²⁾ Double curing time in wet concrete

Fastening injection system ResiFIX VY ECO SF



Fastening in concrete

Permissible loads F_{per} in [kN] in non-cracked concrete C20/25 (Option 7) and cracked concrete C20/25 (Option 1) without influence of spacing and edge distance, installation parameters and unit dimensions. Total safety factors as per ETAG 001 included (γ_M and γ_p). Design according to TR029. See ETA assessment for design and calculations.

Anchor studs RESI AST, VA AST	M8	M10	M12	M16	M20	M24
Drill hole \varnothing d_0 [mm]	10	12	14	18	24	28
Anchorage depth $h_{ef,min}/h_{ef,stand}/h_{ef,max}$ [mm]	60 / 80 / 160	60 / 90 / 200	70 / 110 / 240	80 / 125 / 320	90 / 170 / 400	96 / 210 / 480

Permissible tension load ¹⁾²⁾ [24 °C / 40 °C] ³⁾ in non-cracked concrete (dry or wet)

Zinc plated 5.8	N_{per} [kN]	5,1 / 6,8 / 8,7	6,0 / 9,0 / 13,8	8,4 / 13,2 / 20,0	12,8 / 19,9 / 37,3	17,1 / 33,9 / 58,3	18,8 / 50,3 / 83,9
Stainless steel A4	N_{per} [kN]	5,1 / 6,8 / 9,8	6,0 / 9,0 / 15,5	8,4 / 13,2 / 22,5	12,8 / 19,9 / 41,9	17,1 / 33,9 / 65,5	18,8 / 50,3 / 94,3

Permissible tension load ¹⁾²⁾ [24 °C / 40 °C] ³⁾ in cracked concrete (dry or wet)

Zinc plated 5.8	N_{per} [kN]	2,7 / 3,6 / 7,2	3,4 / 5,0 / 11,2	4,7 / 7,4 / 16,2	7,2 / 11,2 / 28,7	–	–
Stainless steel A4	N_{per} [kN]	2,7 / 3,6 / 7,2	3,4 / 5,0 / 11,2	4,7 / 7,4 / 16,2	7,2 / 11,2 / 28,7	–	–

Permissible tension load ¹⁾²⁾ [50 °C / 80 °C] ³⁾ in non-cracked concrete (dry or wet)

Zinc plated 5.8	N_{per} [kN]	3,9 / 5,2 / 8,7	4,5 / 6,7 / 13,8	6,3 / 9,9 / 20,0	9,6 / 15,0 / 37,3	13,5 / 25,4 / 58,3	17,2 / 37,7 / 83,9
Stainless steel A4	N_{per} [kN]	3,9 / 5,2 / 9,8	4,5 / 6,7 / 15,0	6,3 / 9,9 / 21,5	9,6 / 15,0 / 38,3	13,5 / 25,4 / 59,8	17,2 / 37,7 / 86,2

Permissible tension load ¹⁾²⁾ [50 °C / 80 °C] ³⁾ in cracked concrete (dry or wet)

Zinc plated 5.8	N_{per} [kN]	2,1 / 2,8 / 5,6	2,6 / 3,9 / 8,7	3,7 / 5,8 / 12,6	5,6 / 8,7 / 22,3	–	–
Stainless steel A4	N_{per} [kN]	2,1 / 2,8 / 5,6	2,6 / 3,9 / 8,7	3,7 / 5,8 / 12,6	5,6 / 8,7 / 22,3	–	–

Permissible shear load ¹⁾ in non-cracked concrete

Zinc plated 5.8	V_{per} [kN]	5,2	8,3	12,0	22,4	35,0	45,2 / 50,4 / 50,4
Stainless steel A4	V_{per} [kN]	5,9	9,3	13,5	25,1	39,2	45,2 / 56,5 / 56,5

Permissible shear load ¹⁾ in cracked concrete

Zinc plated 5.8	V_{per} [kN]	5,2 / 5,2 / 5,2	8,1 / 8,3 / 8,3	11,3 / 12,0 / 12,0	17,2 / 22,4 / 22,4	–	–
Stainless steel A4	V_{per} [kN]	5,9 / 5,9 / 5,9	8,1 / 9,3 / 9,3	11,3 / 13,5 / 13,5	17,2 / 25,1 / 25,1	–	–

Permissible bending moment (Zinc plated 5.8)	M_{per} [Nm]	10,7	21,4	37,4	94,9	185,2	320,0
Permissible bending moment (Stainless steel A4)	M_{per} [Nm]	12,0	24,0	41,9	106,4	207,8	359,0

Spacing and edge distance

Spacing	$s_{cr,N}$ [mm]	180 / 240 / 480	180 / 270 / 600	210 / 330 / 720	240 / 375 / 960	270 / 510 / 1200	288 / 630 / 1440
Edge distance	$c_{cr,N}$ [mm]	90 / 120 / 240	90 / 135 / 300	105 / 165 / 360	120 / 188 / 480	135 / 255 / 600	144 / 315 / 720
Minimum spacing	s_{min} [mm]	40	50	60	80	100	120
Minimum edge distance	c_{min} [mm]	40	50	60	80	100	120
Min. thickness of structural part	h_{min} [mm]	$h_{ef} + 30 \text{ mm} \geq 100 \text{ mm}$				$h_{ef} + 2d_0$	
Max. installation torque	$T_{inst} \leq$ [Nm]	10	20	40	80	120	160

¹⁾ Values are valid for $h_{ef,min} / h_{ef,stand} / h_{ef,max}$

²⁾ For higher concrete strengths up to C50/60 the values increase by max. 19%.

³⁾ Max. long term temperature / max. short term temperature after installation. For temperature range 72°C/120°C please see ETA assessment

If underrun the char. spacing or edge distance (c_{cr} or s_{cr}) the loads must be reduced. h_{min} , s_{min} and c_{min} must be observed.

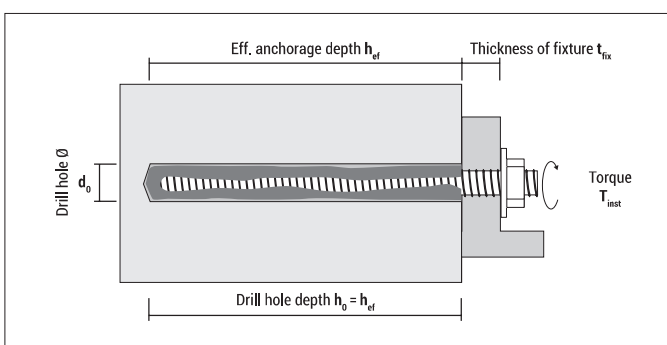

Fastening injection system ResiFIX VY ECO SF



Fastening in masonry (Solid and hollow brick)

Permissible loads in [kN] and installation parameters - selection; for additional brick types and application conditions please see ETA assessment.

Suitable building materials		Density ρ [kg/dm ³]	Compressive strength f_b [N/mm ²]	Anchor studs RESI AST, VA AST Size	Sleeve Size	Min. Anchorage depth h_{ef} [mm]	Use category dry / dry 24°C/40°C ¹⁾ Tension load N_{per} [kN] Shear load V_{per} [kN]	
Solid sand-lime brick KS (NF)		≥ 2,0	≥ 20	M8	without / SH 12-80	80 / 80	1,29 / 1,14	1,29 / 1,14
				M10	without / SH 16-85	90 / 85	1,29 / 1,14	1,29 / 1,29
				M12	without / SH 20-85	100 / 85	1,57 / 1,14	1,43 / 1,43
				M16	without / SH 20-85	100 / 85	1,29 / 1,14	1,43 / 1,43
Solid brick Mz (DF)		≥ 1,6	≥ 20	M8	without / SH 12-80	80 / 80	0,71 / 0,86	1,29 / 1,14
				M10	without / SH 16-85	90 / 85	0,71 / 0,86	1,57 / 1,43
				M12	without / SH 20-85	100 / 85	0,57 / 0,86	2,14 / 1,43
Aerated concrete AAC4		≥ 0,50	≥ 4	M8	without	80	0,32	0,54
				M10	without	90	0,89	0,71
				M12	without	100	0,89	0,89
				M16	without	100	1,25	1,25
Hollow sand-lime brick KSL (KSL 3DF)		≥ 1,4	≥ 12	M8	SH 12-80	80	0,57	0,71
				M10	SH 16-85	85	0,57	1,00
				M10	SH 16-130	130	1,00	1,29
				M12	SH 20-85	85	0,57	1,00
Hollow brick HLz (16DF)		≥ 0,8	≥ 12	M8	SH 12-80	80	0,43	1,00
				M10	SH 16-85	85	0,71	1,71
				M10	SH 16-130	130	1,00	2,29
				M12	SH 20-85	85	1,00	1,71
M16	SH 20-85	85	1,00	1,71				

N_{per}, V_{per} : Permissible loads incl. safety factors (v_M and $v_F = 1,4$), without influence of spacing and edge distance.

Drilling method: KS and Mz: hammer drilling; Aerated concrete, KSL and HLz: rotary drilling

¹⁾ Max. long term temperature / max. short term temperature. Long-term temperature is constant over a longer period of time. The short-term temperature is only present for a short time (day/night change).

Spacing and edge distance

Suitable building materials	Anchor stud	Sleeve	Char. Edge distance c_{cr} [mm]	Min. Edge distance c_{min} [mm]	Char. Spacing parallel to the bearing joint $s_{cr,II}$ [mm]	Char. Spacing perpendicular to the bearing joint $s_{cr,\perp}$ [mm]	Min. Spacing s_{min} [mm]	Max. Torque T_{inst} [Nm]
Solid sand-lime brick KS (NF)	M8	without	120	120	240	240	240	10
	M10	without	135	135	270	270	270	20
	M12	without	150	150	300	300	300	20
	M16	without	150	150	300	300	300	20
Solid brick Mz (DF)	M8	without	120	120	240	240	240	6
	M10	without	135	135	270	270	270	10
	M12	without	150	150	300	300	300	10
Aerated concrete AAC4	M8	without	120	120	240	240	240	2
	M10	without	135	135	270	270	270	2
	M12	without	150	150	300	300	300	2
Hollow sand-lime brick KSL (KSL 3DF)	M8	SH 12-80	100	100	240	240	113*	8
	M10	SH 16-85	100	100	240	240	113*	8
	M10	SH 16-130	100	100	240	240	113*	8
	M12,M16	SH 20-85	120	120	240	240	113*	8
Hollow brick HLz (16DF)	M8	SH 12-80	100	100	497	497	238**	6
	M10	SH 16-85	100	100	497	497	238**	6
	M10	SH 16-130	100	100	497	497	238**	6
	M12,M16	SH 20-85	120	120	497	497	238**	6

Permissible bending moment		Anchor stud			
Steel		M8	M10	M12	M16
Zinc plated 5.8	M_{per} [Nm]	10,8	21,2	37,7	94,9
Stainless steel A4	M_{per} [Nm]	11,9	23,8	42,1	106,2

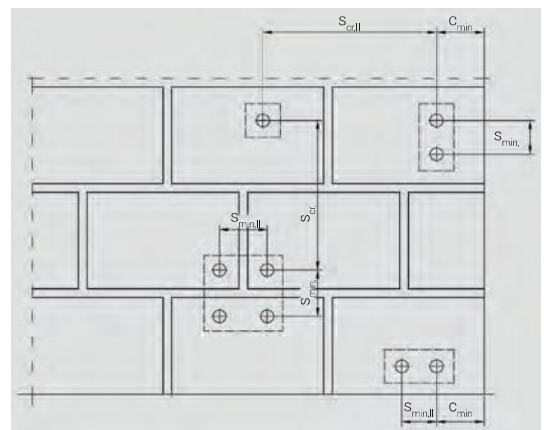

* Values are valid for $s_{min,\perp}$. For $s_{min,II}$ 240 mm is valid.

** Values are valid for $s_{min,\perp}$. For $s_{min,II}$ 497 mm is valid.

Fastening injection system

ResiFIX PYSF



Approvals and certificates



Class A+: Lowest emissions of critical substances in closed spaces

- Harmless to health after curing



Sustainability certification LEED

- Environmentally friendly, low-pollutant, low-emission and sustainable construction product

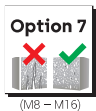

European Technical Assessment Option 7 for non-cracked concrete (M8 - M16)

- For standard applications in concrete



Usage also in water-filled drill holes

- Extended range of applications



Good load values at a very good **price-performance ratio**



European Technical Assessment for masonry (M8 - M16)

- For more application flexibility



Styrene free

- Reduced odour exposure

Fastening injection system ResiFIX PYSF



Polyester PYSF (styrene free)

Type	Art-No	Content [ml]	Mixings nozzles included [pcs]	Shelf life [months]		€ / pc	[pcs]
PY 300 SF	300PSF	300	1	12	●		12
PY 345 SF	345PSF	345	1	18	●		12
PY 410 SF	410PYSF	410	1	18	●		12



ResiFIX PYSF (styrene free)

Type	Art-No	Content [ml]		€ / pc	[pcs]	[Blister]
PY 165 SF	165PSF	165	●		1	12

Incl. 2 mixings nozzles MD

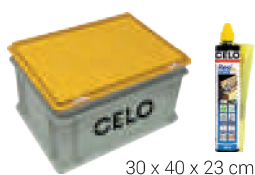

30 x 40 x 23 cm

Universal box with ResiFIX PY 300 SF, PY 345 SF

Type	Art-No	Content [cartridges]	Mixings nozzles included [pcs]	Shelf life [months]		€ / box	[pcs]
PY 300 SF in universal box	SYS300PSF20	20	20	12	●		1
PY 345 SF in universal box	SYS345PSF20	20	20	18	●		1

Curing times ResiFIX Polyester PYSF

Temperature of building material	[°C]	> -10	> -5	> 0	> +5	> +10	> +20	> +30	> +40
Max. working time	[min]	–	90	45	25	20	6	4	1,5
Min. curing time ¹⁾	[min]	–	6h	3h	2h	100	45	25	15

¹⁾ Double curing time in wet concrete

Fastening injection system ResiFIX PYSF



Fastening in concrete

Permissible loads F_{per} in [kN] in non-cracked concrete C20/25 for single anchor without influence of spacing and edge distance, installation parameters and unit dimensions. Total safety factors as per ETAG 001 included (γ_M and γ_F). See ETA assessment for design and calculations.

Anchor studs RESI AST, VA AST	M8	M10	M12	M16
Drill hole \varnothing d_0 [mm]	10	12	14	18
Anchorage depth $h_{ef,min} / h_{ef,stand} / h_{ef,max}$ [mm]	60 / 80 / 160	60 / 90 / 200	70 / 110 / 240	80 / 125 / 320

Permissible tension load ¹⁾²⁾ [24 °C / 40 °C] ³⁾ in non-cracked concrete [dry or wet]

Zinc plated 5.8	N_{per} [kN]	5,1 / 6,8 / 8,7	6,0 / 9,0 / 13,8	8,4 / 13,2 / 20,0	12,8 / 19,9 / 37,3
Stainless steel A4	N_{per} [kN]	5,1 / 6,8 / 9,8	6,0 / 9,0 / 15,5	8,4 / 13,2 / 22,5	12,8 / 19,9 / 41,9

Permissible shear load [24 °C / 40 °C] ³⁾

Zinc plated 5.8	V_{per} [kN]	5,2	8,3	12,0	22,4
Stainless steel A4	V_{per} [kN]	5,9	9,3	13,5	25,1
Permissible bending moment (Zinc plated 5.8)	M_{per} [Nm]	10,7	21,4	37,4	94,9
Permissible bending moment (Stainless steel A4)	M_{per} [Nm]	12,0	24,0	41,9	106,4

Spacing and edge distance

Spacing	$s_{cr,N}$ [mm]	180 / 240 / 480	180 / 270 / 600	210 / 330 / 720	240 / 375 / 960
Edge distance	$c_{cr,N}$ [mm]	90 / 120 / 240	90 / 135 / 300	105 / 165 / 360	120 / 188 / 480
Minimum spacing	s_{min} [mm]	40	50	60	80
Minimum edge distance	c_{min} [mm]	40	50	60	80
Min. thickness of structural part	h_{min} [mm]	$h_{ef} + 30 \text{ mm} \geq 100 \text{ mm}$			$h_{ef} + 2d_0$
Max. installation torque	$T_{inst} \leq$ [Nm]	10	20	40	80

¹⁾ Values are valid for $h_{ef,min} / h_{ef,stand} / h_{ef,max}$

²⁾ For higher concrete strengths up to C50/60 the values increase by max. 19%.

³⁾ Max. long term temperature / max. short term temperature after installation. For temperature range 50°C/80°C please see ETA assessment
If underrun the char. spacing or edge distance (c_{cr} or s_{cr}) the loads must be reduced. h_{min} , s_{min} and c_{min} must be observed.

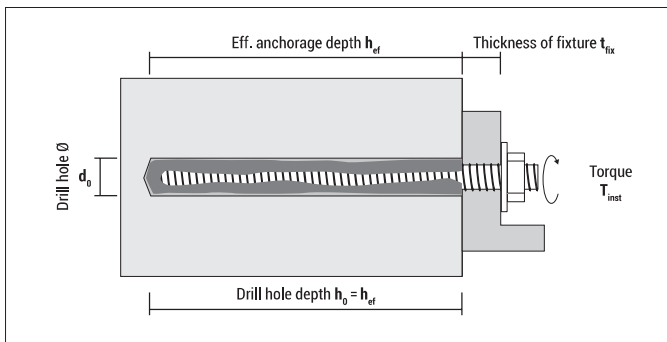

Fastening injection system ResiFIX PYSF



Fastening in masonry (Solid and hollow brick)

Permissible loads in [kN] and installation parameters - selection; for additional brick types and application conditions please see ETA assessment.

Suitable building materials	Density ρ [kg/dm ³]	Compressive strength f_b [N/mm ²]	Anchor studs	Sleeve	Min. Anchorage depth h_{ef} [mm]	Use category dry / dry 24°C/40°C ¹⁾		
			RESI AST, VA AST			Tension load N_{per} [kN]	Shear load V_{per} [kN]	
			Size	Size				
Solid sand-lime brick KS (NF)		≥ 2,0	≥ 20	M8	without / SH 12-80	80 / 80	1,29 / 1,14	1,29 / 1,14
				M10	without / SH 16-85	90 / 85	1,29 / 1,14	1,29 / 1,29
				M12	without / SH 20-85	100 / 85	1,60 / 1,14	1,43 / 1,43
				M16	without / SH 20-85	100 / 85	1,29 / 1,14	1,43 / 1,43
Solid brick Mz (DF)		≥ 1,64	≥ 20	M8	without / SH 12-80	80 / 80	0,71 / 0,86	1,29 / 1,14
				M10	without / SH 16-85	90 / 85	0,71 / 0,86	1,57 / 1,43
				M16	without / SH 20-85	100 / 85	1,00 / 0,86	2,14 / 1,43
Aerated concrete AAC4		≥ 0,50	≥ 4	M8	without	80	0,32	0,54
				M10	without	90	0,89	0,71
				M12	without	100	0,89	0,89
				M16	without	100	1,25	1,25
Hollow sand-lime brick KSL (KSL 3DF)		≥ 1,4	≥ 12	M8	SH 12-80	80	0,57	0,71
				M10	SH 16-85	85	0,57	1,00
				M10	SH 16-130	130	1,00	1,29
				M12	SH 20-85	85	0,57	1,00
Hollow brick HLz (16DF)		≥ 0,83	≥ 12	M8	SH 12-80	80	0,43	1,00
				M10	SH 16-85	85	0,71	1,71
				M10	SH 16-130	130	1,00	2,30
				M12	SH 20-85	85	1,00	1,71
				M16	SH 20-85	85	1,00	1,71

N_{per} , V_{per} : Permissible loads incl. safety factors (γ_M and $\gamma_F = 1,4$), without influence of spacing and edge distance.

Drilling method: KS and Mz: hammer drilling; Aerated concrete, KSL and HLz: rotary drilling

¹⁾ Max. long term temperature / max. short term temperature. Long-term temperature is constant over a longer period of time.

The short-term temperature is only present for a short time (day/night change).

Spacing and edge distance

Suitable building materials	Anchor stud	Sleeve	Char. Edge distance c_{cr} [mm]	Min. Edge distance c_{min} [mm]	Char. Spacing parallel to the bearing joint $s_{cr,II}$ [mm]	Char. Spacing perpendicular to the bearing joint $s_{cr,\perp}$ [mm]	Min. Spacing s_{min} [mm]	Max. Torque T_{inst} [Nm]
Solid sand-lime brick KS (NF)	M8	without	120	120	240	240	240	10
	M10	without	135	135	270	270	270	20
	M12	without	150	150	300	300	300	20
	M16	without	150	150	300	300	300	20
Solid brick Mz (DF)	M8	without	120	120	240	240	240	6
	M10	without	135	135	270	270	270	10
	M12	without	150	150	300	300	300	10
Aerated concrete AAC4	M8	without	120	120	240	240	240	2
	M10	without	135	135	270	270	270	2
	M12	without	150	150	300	300	300	2
Hollow sand-lime brick KSL (KSL 3DF)	M8	SH 12-80	100	100	240	240	113*	8
	M10	SH 16-85	100	100	240	240	113*	8
	M10	SH 16-130	100	100	240	240	113*	8
Hollow brick HLz (16DF)	M12,M16	SH 20-85	120	120	240	240	113*	8
	M8	SH 12-80	100	100	497	497	238**	6
	M10	SH 16-85	100	100	497	497	238**	6
	M10	SH 16-130	100	100	497	497	238**	6
	M12,M16	SH 20-85	120	120	497	497	238**	6

Permissible bending moment

		Anchor stud			
		M8	M10	M12	M16
Steel					
Zinc plated 5.8	M_{per} [Nm]	10,9	21,1	37,1	94,9
Stainless steel A4	M_{per} [Nm]	11,9	23,8	42,1	106,2

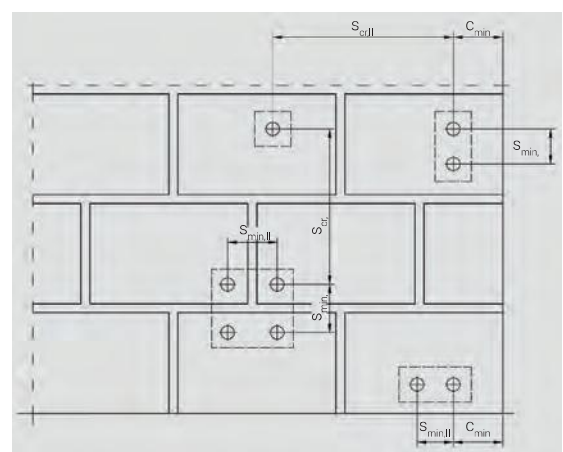

* Values are valid for $s_{min,\perp}$. For $s_{min,II}$ 240 mm is valid.

** Values are valid for $s_{min,\perp}$. For $s_{min,II}$ 497 mm is valid.

Fastening injection system

ResiFIX

Pure Epoxy



Approvals and certificates



European Technical Assessment
Option 1 for cracked concrete
(M8 - M30, Ø8 - Ø32)



European Technical Assessment
for post-installed rebar
connections (Ø8 - Ø25)



Class A+: Lowest emissions of critical substances in closed spaces

- Harmless to health after curing



Sustainability certification LEED

- Environmentally friendly, low-pollutant, low-emission and sustainable construction product



Usage under seismic conditions

- Tested for use in areas with high risk of earthquakes



European Technical Assessment Option 1 for cracked and non-cracked concrete (M8 - M30)

- For a wide range of safety critical applications



One mixing nozzle and one extension tube are always included

- Deeper drill holes can also be filled



Very high load values

- Heavy-duty usage



Usage also in water-filled drill holes and suitable for contact with drinking water

- Extended range of applications



Fire resistance test R120

- Fulfills fire protection requirements

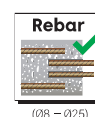

European Technical Assessment post-installed rebar connections (Ø8 - Ø25)

- For more application flexibility



Styrene free

- Reduced odour exposure



Pure Epoxy BRSF (styrene free)

Type	Art-No	Content [ml]	Mixings nozzles included [pcs]	Mixings nozzle extension [200mm] incl. [pcs]	Shelf life [months]	ETA	€ / pc	[pcs]
BR 385 SF	385CRPE	385	1	1	24	●		12
BR 585 SF	585CRPE	585	1	1	24	●		12
BR 1400 SF	1400CRPE	1400	1	1	24	●		12

Delivery only on request

Curing times ResiFIX Pure Epoxy BRSF

Temperature of building material	[°C]	> -10	> -5	> 0	> +5	> +10	> +20	> +30	> +40
Max. working time	[min]	–	–	–	120	90	30	20	12
Min. curing time ¹⁾	[min]	–	–	–	50h	30h	10h	6h	4h

¹⁾ Double curing time in wet concrete

Fastening in concrete

Permissible loads F_{per} in [kN] in non-cracked concrete C20/25 (Option 7) and cracked concrete C20/25 (Option 1) without influence of spacing and edge distance, installation parameters and unit dimensions. Total safety factors as per ETAG 001 included (γ_M and γ_R). Design according to TR029. See ETA assessment for design and calculations.

Anchor studs RESI AST, VA AST	M8	M10	M12	M16	M20	M24	M 27	M30
Drill hole Ø d_0 [mm]	10	12	14	18	24	28	30	35
Anchorage depth $h_{ef,min} / h_{ef,stand} / h_{ef,max}$ [mm]	60 / 80 / 96	60 / 90 / 120	70 / 110 / 144	80 / 125 / 192	90 / 170 / 240	96 / 210 / 288	108 / 240 / 324	120 / 280 / 360

Permissible tension load ^{1) 2)} [24 °C / 40 °C] ³⁾ in non-cracked concrete (dry or wet)

Zinc plated 5.8	N_{per} [kN]	8,7 / 8,7 / 8,7	9,3 / 13,8 / 13,8	11,7 / 20,0 / 20,0	14,3 / 28,0 / 37,3	14,7 / 38,1 / 58,3	16,2 / 52,3 / 83,9	19,8 / 63,9 / 98,8	22,6 / 80,5 / 117,3
Stainless steel A4	N_{per} [kN]	9,0 / 9,8 / 9,8	9,3 / 15,5 / 15,5	11,7 / 22,5 / 22,5	14,3 / 28,0 / 41,9	14,7 / 38,1 / 63,9	16,2 / 52,3 / 84,0	19,8 / 57,4 / 57,4	22,6 / 70,0 / 70,0

Permissible tension load ^{1) 2)} [24 °C / 40 °C] ³⁾ in cracked concrete (dry or wet)

Zinc plated 5.8	N_{per} [kN]	4,2 / 5,6 / 6,7	5,2 / 7,9 / 10,5	7,9 / 12,3 / 16,2	10,2 / 16,2 / 24,9	10,5 / 21,8 / 30,8	11,5 / 29,6 / 40,6	14,1 / 38,1 / 50,8	16,1 / 49,4 / 63,5
Stainless steel A4	N_{per} [kN]	4,2 / 5,6 / 6,7	5,2 / 7,9 / 10,5	7,9 / 12,3 / 16,2	10,2 / 16,2 / 24,9	10,5 / 21,8 / 30,8	11,5 / 29,6 / 40,6	14,1 / 38,1 / 50,8	16,1 / 49,4 / 63,5

Permissible tension load ^{1) 2)} [43 °C / 60 °C] ³⁾ in non-cracked concrete (dry or wet)

Zinc plated 5.8	N_{per} [kN]	5,7 / 7,6 / 8,7	7,1 / 10,7 / 13,8	9,4 / 14,8 / 19,4	13,6 / 21,2 / 32,6	14,7 / 29,1 / 41,0	16,2 / 40,4 / 55,4	19,8 / 51,9 / 69,2	22,6 / 67,3 / 86,6
Stainless steel A4	N_{per} [kN]	5,7 / 7,6 / 9,1	7,1 / 10,7 / 14,2	9,4 / 14,8 / 19,4	13,6 / 21,2 / 32,6	14,7 / 29,1 / 41,0	16,2 / 40,4 / 55,4	19,8 / 51,9 / 67,4	22,6 / 67,3 / 70,0

Permissible tension load ^{1) 2)} [43 °C / 60 °C] ³⁾ in cracked concrete (dry or wet)

Zinc plated 5.8	N_{per} [kN]	2,7 / 3,6 / 4,3	3,4 / 5,0 / 6,7	4,7 / 7,4 / 9,7	6,4 / 10,0 / 15,3	6,7 / 12,7 / 18,0	8,6 / 18,8 / 25,9	11,1 / 24,2 / 32,3	13,5 / 31,4 / 40,4
Stainless steel A4	N_{per} [kN]	2,7 / 3,6 / 4,3	3,4 / 5,0 / 6,7	4,7 / 7,4 / 9,7	6,4 / 10,0 / 15,3	6,7 / 12,7 / 18,0	8,6 / 18,8 / 25,9	11,1 / 24,2 / 32,3	13,5 / 31,4 / 40,4

Permissible shear load ¹⁾ in non-cracked concrete

Zinc plated 5.8	V_{per} [kN]	5,2	8,3	12,0	22,4	35,0	45,2 / 50,4 / 50,4	55,5 / 65,6 / 65,6	63,2 / 80,1 / 80,1
Stainless steel A4	V_{per} [kN]	5,9	9,3	13,5	25,1	39,2	45,2 / 56,5 / 56,5	34,5 / 34,5 / 34,5	42,1 / 42,1 / 42,1

Permissible shear load ¹⁾ in cracked concrete

Zinc plated 5.8	V_{per} [kN]	5,2	8,3	12,0	22,4 / 22,4 / 22,4	29,3 / 35,0 / 35,0	32,2 / 50,4 / 50,4	39,6 / 65,6 / 65,6	45,1 / 80,1 / 80,1
Stainless steel A4	V_{per} [kN]	5,9	9,3	13,5	24,5 / 25,1 / 25,1	29,3 / 39,2 / 39,2	32,2 / 56,5 / 56,5	34,5 / 34,5 / 34,5	42,1 / 42,1 / 42,1

Permissible bending moment (Zinc plated 5.8)	M_{per} [Nm]	10,7	21,4	37,4	94,9	185,2	320,0	476,2	642,1
Permissible bending moment (Stainless steel A4)	M_{per} [Nm]	12,0	24,0	41,9	106,4	207,8	359,0	250,1	337,2

Spacing and edge distance

Spacing	$s_{cr,N}$ [mm]	180 / 240 / 288	180 / 270 / 360	210 / 330 / 432	240 / 375 / 576	270 / 510 / 720	288 / 630 / 864	324 / 720 / 972	360 / 840 / 1080
Edge distance	$c_{cr,N}$ [mm]	90 / 120 / 144	90 / 135 / 180	105 / 165 / 216	120 / 188 / 288	135 / 255 / 360	144 / 315 / 432	162 / 360 / 486	180 / 420 / 540
Minimum spacing	s_{min} [mm]	40	50	60	80	100	120	135	150
Minimum edge distance	c_{min} [mm]	40	50	60	80	100	120	135	150
Min. thickness of concrete	h_{min} [mm]	$h_{ef} + 30 \text{ mm} \geq 100 \text{ mm}$				$h_{ef} + 2d_0$			
Max. installation torque	$T_{inst} \leq$ [Nm]	10	20	40	80	120	160	180	200

¹⁾ Values are valid for $h_{ef,min} / h_{ef,stand} / h_{ef,max}$

²⁾ For higher concrete strengths up to C50/60 the values increase by max. 10%.

³⁾ Max. long term temperature / max. short term temperature after installation. For temperature range 43°C/72°C please see ETA assessment

If underrun the char. spacing or edge distance (C_{cr} or S_{cr}) the loads must be reduced. h_{min} , S_{min} and C_{min} must be observed.

ResiFIX Manual dispenser



APP300



- High force transmission of 1:25 and so **noticeably reduced force expenditure**
- **Robust manual dispenser** made out of metal
- Also suitable for **all standard cartridges**, e.g. commercial adhesives and sealants (silicone, MS Polymer)
- Reduced weight - **improved working comfort**
- **The cartridge area is rotatable 360°** which facilitates the usage of sealants especially in corners

Manual dispenser APP 300

Type	Art-No	Suitable for ResiFIX Type	€ / pc	[pcs]
APP 300	300APP	300 / 165 / 280		1



APVM



- High force transmission of 1:25 and so **noticeably reduced force expenditure**
- **Robust manual dispenser** made out of metal
- Low weight due to the use of magnesium **only 680 g light**; therefore increased working comfort
- Suitable for **side-by-side cartridges with 345 ml content**. Also suitable for standard cartridges with 165 ml, 280 ml, 300 ml to read the scale units of ResiFIX; outer rod serves as a pointer

Manual dispenser APVM

Type	Art-No	Suitable for ResiFIX Type	€ / pc	[pcs]
APVM	345APVM	345 / 300 / 280 / 165		1



APP380



- High force transmission of 1:25 and so **noticeably reduced force expenditure**
- **Robust manual dispenser** made out of metal
- Suitable for **ResiFIX cartridges with 410 ml**

Manual dispenser APP 380

Type	Art-No	Suitable for ResiFIX Type	€ / pc	[pcs]
APP 380	380APP	410		1



OL385



Manual dispenser OL for ResiFIX Pure Epoxy

Type	Art-No	Suitable for ResiFIX Type	€ / pc	[pcs]
OL 385	385OL	385 / 585		1

Fastening injection system ResiFIX - Accessories



Mixing nozzle MD transparent

Type	Art-No	Suitable cartridges	€/pc	[pcs]	[pcs]
MD	9MRMEA	all, except Pure Epoxy BR SF		20	-



Mixings nozzle extension MDV for MD

Type	Art-No	Outer Ø [mm]	Length [mm]	€/pc	[pcs]	[pcs]
MDV 10	9MDV	10	200		10	-
MDV 7,5*	975MDV	7,5	200		10	-

* Especially suitable for metal sleeve SH 12-100 (see page 172)



Cleaning brush RBK made of nylon, for masonry (with wooden handle)

Type	Art-No	Length [mm]	Suitable for hole-Ø [mm]	€/pc	[pcs]	[pcs]
RBK Ø20	9PLRBK	300	20		5	-



Cleaning brush RBS made of steel, for concrete

Type	Art-No	Length [mm]	Suitable for hole-Ø [mm]	Suitable for anchor stud	Connecting thread	€/pc	[pcs]	[pcs]
RBS Ø12	9M12RBK	170	10	M8	M6		5	-
RBS Ø14	9M14RBK	170	12	M10	M6		5	-
RBS Ø16	9M16RBK	200	14	M12	M6		5	-
RBS Ø20	9M20RBK	200	18	M16	M6		5	-
RBS Ø26	9M26RBK	250	24	M20	M6		5	-
RBS Ø30	9M30RBK	300	28	M24	M6		5	-



Handle and Extension for RBS

Type	Art-No	Length [mm]	Suitable for RBS Ø	Connecting thread	€/pc	[pcs]	[pcs]
MRBKV	MRBKV	140	all	M6		5	-
MRBKH	MRBKH	-	all	M6		5	-



Blow out pump AB

Type	Art-No	Tube-Ø [mm]	€/pc	[pcs]	[pcs]
AB	BOP	8		1	-

Fastening injection system ResiFIX - Accessories



Plastic sleeves SH

Type	Art-No	d_0 [mm]	L_d [mm]	h_0 [mm]	Suitable for thread \emptyset	€ / 100 pcs	[pcs]	[pcs]
SH 12-60 ¹⁾	91260SH	12	60	65	M6, M8		24	432
SH 12-80	91280SH	12	80	85	M6, M8		24	432
SH 16-85	91585SH	16	85	90	M8, M10		12	216
SH 16-130	915130SH	16	130	135	M8, M10		12	144
SH 20-85	92085SH	20	85	90	M12, M16		12	216
SH 20-130	920130SH	20	130	135	M12, M16		20	160
SH 20-200	920200SH	20	200	205	M12, M16		20	160

Note: The system (resin, sleeve and anchor rod) is only approved completely if approved components are used.

1) Not part of the ResiFIX ETA assessments



Metal sleeves SH-1000 can be cut individually (length 1m)

Type	Art-No	d_0 [mm]	h_0 [mm]	Suitable for thread \emptyset	€ / pcs	[pcs]	[pcs]
SH 12-1000	12TMRMEA	12	flexible	M6 – M8		10	–
SH 16-1000	16TMRMEA	16	flexible	M8 – M12		10	–
SH 22-1000	22TMRMEA	22	flexible	M12 – M16		8	–



Internal threaded sleeves IGH

Type	Art-No	d_0 [mm]	h_0 [mm]	Suitable for thread \emptyset	Thread L* [mm]	Outer \emptyset [mm]	Suitable for sleeve	€ / 100 pcs	[pcs]	[pcs]
IGH M8-80	9880IGH	14	90	M8	26	12	SH 16-85 SH 20-85		12	324
IGH M10-80	91080IGH	16	90	M10	26	14	SH 20-85		12	324
IGH M12-80	91280IGH	18	90	M12	26	16	SH 20-85		12	324

*Internal thread length

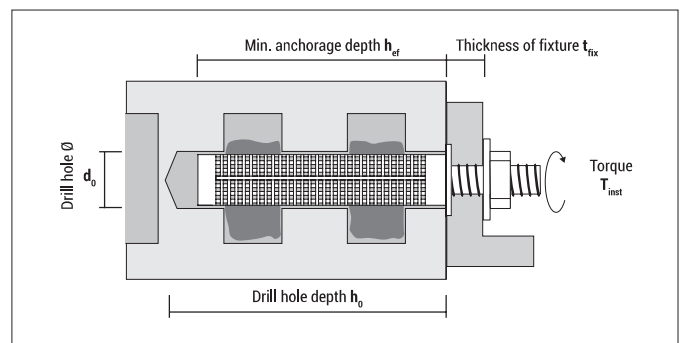
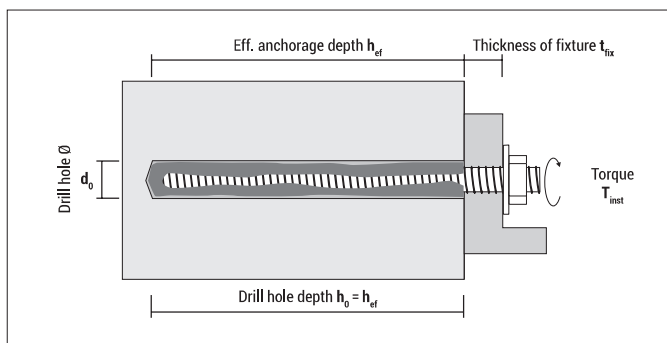

ResiFIX Anchor studs

Approvals and certificates



RESI AST, zinc plated 5.8 with nut and washer

Type $d_s - L$	Art-No	in concrete					in solid brick		in hollow brick		€/ 100 pcs		
		d_0 [mm]	$h_{ef, min}$ [mm]	$t_{fix, max}$ for $h_{ef, min}$ [mm]	$h_{ef, Stand}^{1)}$ [mm]	$t_{fix, max}$ for $h_{ef, stand}$ [mm]	$d_0 - h_0$ [mm]	$t_{fix, max}$ [mm]	Sleeve [Type]	$t_{fix, max}$ [mm]			
M8-110	98110RAST	10	60	40	80	20	10-80	20	SH 12-80	20	10	100	
M8-130	98130RAST	10	60	60	80	40	10-80	40	SH 12-80	40	10	100	
M10-110	910110RAST	12	60	40	90	10	12-90	10	SH 16-85	15	10	100	
M10-130	910130RAST	12	60	60	90	30	12-90	30	SH 16-85	35	10	100	
M10-170	910170RAST	12	60	100	90	70	12-90	70	SH 16-85	75	10	100	
M10-200	910200RAST	12	60	130	90	100	12-90	100	SH 16-85	105	10	60	
M12-130	912130RAST	14	70	45	110	5	14-100	15	SH 20-85	30	10	100	
M12-160	912160RAST	14	70	75	110	35	14-100	45	SH 20-85	60	10	100	
M12-210	912210RAST	14	70	125	110	85	14-100	95	SH 20-85	110	10	60	
M16-160	916160RAST	18	80	60	125	15	18-100	40	SH 20-85	60	10	60	
M16-190	916190RAST	18	80	90	125	45	18-100	70	SH 20-85	90	10	60	
M16-235	916235RAST	18	80	135	125	90	18-100	115	SH 20-85	135	10	40	
M20-240	920240RAST	24	90	130	170	50	not suitable		not suitable		5	20	
M24-300	924300RAST	28	96	180	210	65	not suitable		not suitable		5	20	



RESI AST, stainless steel A4 with nut and washer



Type $d_s - L$	Art-No	in concrete					in solid brick		in hollow brick		€/ 100 pcs		
		d_0 [mm]	$h_{ef, min}$ [mm]	$t_{fix, max}$ for $h_{ef, min}$ [mm]	$h_{ef, Stand}^{1)}$ [mm]	$t_{fix, max}$ for $h_{ef, stand}$ [mm]	$d_0 - h_0$ [mm]	$t_{fix, max}$ [mm]	Sleeve [Type]	$t_{fix, max}$ [mm]			
M8-110	9X8110RAST	10	60	40	80	20	10-80	20	SH 12-80	20	10	100	
M8-130	9X8130RAST	10	60	60	80	40	10-80	40	SH 12-80	40	10	100	
M10-110	9X10110RAST	12	60	40	90	10	12-90	10	SH 16-85	15	10	100	
M10-130	9X10130RAST	12	60	60	90	30	12-90	30	SH 16-85	35	10	100	
M10-170	9X10170RAST	12	60	100	90	70	12-90	70	SH 16-85	75	10	100	
M10-200	9X10200RAST	12	60	130	90	100	12-90	100	SH 16-85	105	10	60	
M12-130	9X12130RAST	14	70	45	110	5	14-100	15	SH 20-85	30	10	100	
M12-160	9X12160RAST	14	70	75	110	35	14-100	45	SH 20-85	60	10	100	
M12-210	9X12210RAST	14	70	125	110	85	14-100	95	SH 20-85	110	10	60	
M16-160	9X16160RAST	18	80	60	125	15	18-100	40	SH 20-85	60	10	60	
M16-190	9X16190RAST	18	80	90	125	45	18-100	70	SH 20-85	90	10	60	
M16-235	9X16235RAST	18	80	135	125	90	18-100	115	SH 20-85	135	10	40	
M20-240	9X20240RAST	24	90	130	170	50	not suitable		not suitable		5	20	
M24-300	9X24300RAST	28	96	180	210	65	not suitable		not suitable		5	20	

Also suitable for ResiFIX: Anchor studs VA AST for the bonded anchor (with outer hexagon)

Further lengths, steel 8.8, hot-dip galvanized steel and stainless steel HCR on request

1) Standard anchorage depth means the usually used anchorage depth. Min. anchorage depth according to ETA assessments



incl.

Heavy-duty sleeve ResiTHERM® S Set for heavy-duty applications in hollow / perforated bricks

Type	Art-No	Set contains (packed in bag)	L [mm]	Thickness of insulation material h _D [mm]	€ / Set	[Set]	[Sets]
RTH S	RTHS2	2x ResiTHERM® S 2x Threaded stud M12x70 mm, Stainless steel A4 2x Washer M12 DIN 125, Stainless steel A4 2x Hexagon nut M12 DIN 934, Stainless steel A4 1x ResiFIX VY300SF	125	0		1	10

For further information, technical data see page 182



Blister IGH

Type	Art-No	d ₀ [mm]	h ₀ [mm]	Suitable for thread Ø	Outer Ø [mm]	€ / Blister	[pcs]	[Blister]
IGH M8-80	5880IGHM4	14	90	M8	12		4	10
IGH M10-80	51080IGHM4	16	90	M10	14		4	10



with centering cap



Blister SH

Type	Art-No	d ₀ [mm]	h ₀ [mm]	Suitable for thread Ø	€ / Blister	[pcs]	[Blister]
SH 12-80	51280SH4	12	85	M6, M8		4	10
SH 16-85	51685SH4	16	90	M8, M10		4	10
SH 16-130	515130SH4	16	135	M8, M10		4	10
SH 20-85	52085SH4	20	90	M12, M16		4	10

Note: The system (resin, sleeve and anchor rod) is only approved completely if approved components are used.



Blister RESI AST, zinc plated

Type	Art-No	Thread	Length L [mm]	€ / Blister	[pcs]	[Blister]
8-110	58110VMAS4	M8	110		4	10
10-130	510130VMAS4	M10	130		4	10
12-160	512160VMAS4	M12	160		4	10

Note: The system (resin, sleeve and anchor rod) is only approved completely if approved components are used.



Distance mounting system ResiTHERM®



Advantages



ResiTHERM® 200



ResiTHERM® 160



ResiTHERM® 120

- The perfect solution for distance installations in hollow bricks
- Heavy-duty system for fastening of awnings, canopies, french balconies, railings, satellite dishes etc. in ETICS
- Excellent thermal separation, almost no thermal bridge
- Outstanding high values in hollow bricks
- Easy and fast installation saves time and money
- Product is ready to use: available in three standard lengths
- Suitable for large insulation thickness up to 200 mm
- For non-insulated hollow brick walls: **ResiTHERM® S** (p. 178)
- ResiTHERM® was tested together with the injection system ResiFIX VYSF

Approvals and certificates



Mounting

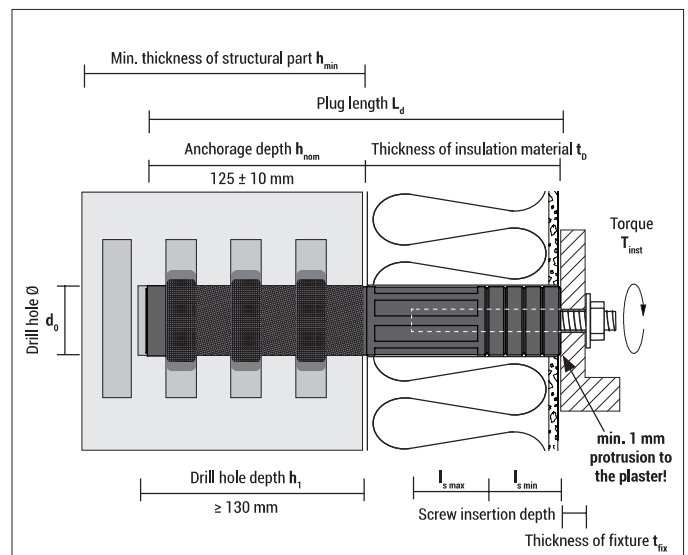

Suitable building materials

Very suitable

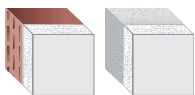

- Hollow brick
- Aerated concrete

Suitable to a limited extent



- Hollow sand-lime brick
- Solid brick
- Solid sand-lime brick
- Concrete

Distance mounting system ResiTHERM®

Mounting in hollow brick

1. Put drilling aid on core bit; drill with cordless screwdriver (without impact) through the insulation material up to the hollow brick wall (remove drilling aid after the first 10 mm)
2. Measure the thickness of the insulation and cut ResiTHERM® if needed (max. 40 mm)
3. Put drilling aid on core bit and drill min. 130 mm into the hollow brick wall (remove drilling aid after the first 10 mm)
4. Clean hole
5. Press ResiTHERM® onto mixing nozzle and push it carefully into the drill hole
6. Fill ResiTHERM® with injection system ResiFIX; the end of the filling process can be clearly felt
7. Respect curing time
8. Fill annular gap with sealant StickFX XP, MS Polymer
9. Install fixture $T_{inst} \leq 20 \text{ Nm}$

Isothermic profile

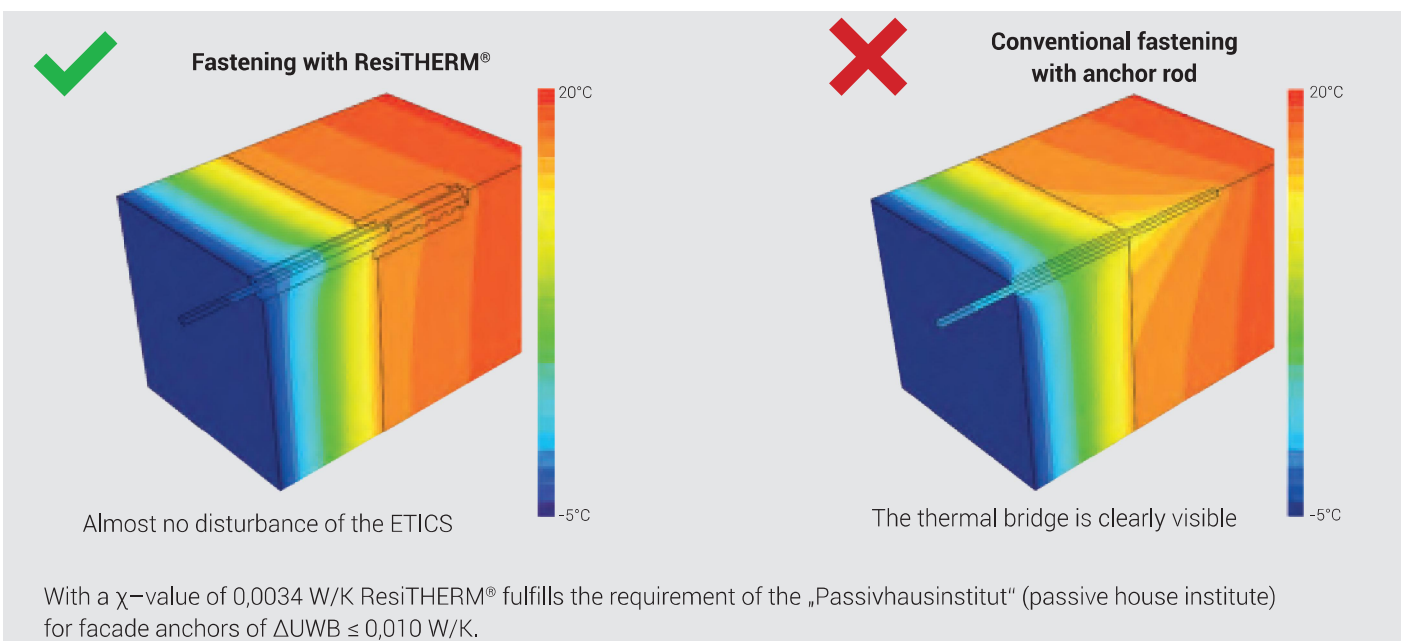

Distance mounting system ResiTHERM®



Starter set ResiTHERM® in universal box (30 x 40 x 23 cm)

Type	Art-No	Starter set ResiTHERM® contains			€/box	[box]
		ResiTHERM®	Art-No Accessories	Accessories		
SYS120RTH4	Starter set RTH 120	4x ResiTHERM® 120	–	4x Threaded stud M12x70 mm, stainless steel A4 4x Washer M12 DIN 125, stainless steel A4 4x Hexagon nut M12 DIN 934, stainless steel A4		1
SYS160RTH4	Starter set RTH 160	4x ResiTHERM® 160	+	300VSF 39ABH 39220BST 100M16AD 200M16AD BL290MSXP 1x StickFX XP white, MS Polymer		1
SYS200RTH4	Starter set RTH 200	4x ResiTHERM® 200	–	1x Manual dispenser APVM 50x Distance washer DIN 9021 for M12 (13x37x3 mm) 1 pair work gloves		1

¹⁾ ResiTHERM® may be cut up to 40 mm if needed.
Longer lengths of ResiTHERM® on request.



ResiTHERM® 200 for insulation thicknesses 160 - 200 mm

Type	Art-No	Set contains (packed in bag)	L [mm]	Thickness of insulation material $t_b^{1)}$ [mm]	€/Set	[Set]	[Sets]
RTH 200	200RTH2	2x ResiTHERM® 200 2x Threaded stud M12x70 mm, stainless steel A4 2x Washer M12 DIN 125, stainless steel A4 2x Hexagon nut M12 DIN 934, stainless steel A4 1x ResiFIX VY300SF	325	160 - 200		1	10

¹⁾ ResiTHERM® may be cut up to 40 mm if needed.
Longer lengths of ResiTHERM® on request.



ResiTHERM® 160 for insulation thicknesses 120 - 160 mm

Type	Art-No	Set contains (packed in bag)	L [mm]	Thickness of insulation material $t_b^{1)}$ [mm]	€/Set	[Set]	[Sets]
RTH 160	160RTH2	2x ResiTHERM® 160 2x Threaded stud M12x70 mm, stainless steel A4 2x Washer M12 DIN 125, stainless steel A4 2x Hexagon nut M12 DIN 934, stainless steel A4 1x ResiFIX VY300SF	285	120 - 160		1	10

¹⁾ ResiTHERM® may be cut up to 40 mm if needed.

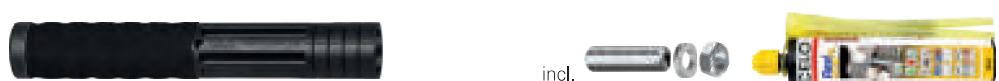

ResiTHERM® 120 for insulation thicknesses 80 - 120 mm

Type	Art-No	Set contains (packed in bag)	L [mm]	Thickness of insulation material $t_b^{1)}$ [mm]	€/Set	[Set]	[Sets]
RTH 120	120RTH2	2x ResiTHERM® 120 2x Threaded stud M12x70 mm, stainless steel A4 2x Washer M12 DIN 125, stainless steel A4 2x Hexagon nut M12 DIN 934, stainless steel A4 1x ResiFIX VY300SF	245	80 - 120		1	10

¹⁾ ResiTHERM® may be cut up to 40 mm if needed.

Heavy-duty sleeve ResiTHERM® S



Advantages



- The perfect solution for heavy-duty applications in hollow / perforated brick walls (not insulated)
- Heavy-duty system for fastening of awnings, canopies, french balconies, railings, satellite dishes etc.
- Outstanding high values also in thin-walled perforated bricks
- Excellent thermal separation, almost no thermal bridge
- For insulated hollow brick walls use **ResiTHERM® (S. 175)**
- ResiTHERM was tested together with the injection system ResiFIX VYSF

Approvals and certificates



Suitable building materials

Very suitable



- Hollow brick
- Aerated concrete

Suitable to a limited extent



- Hollow sand-lime brick
- Solid brick
- Solid sand-lime brick
- Concrete

Mounting

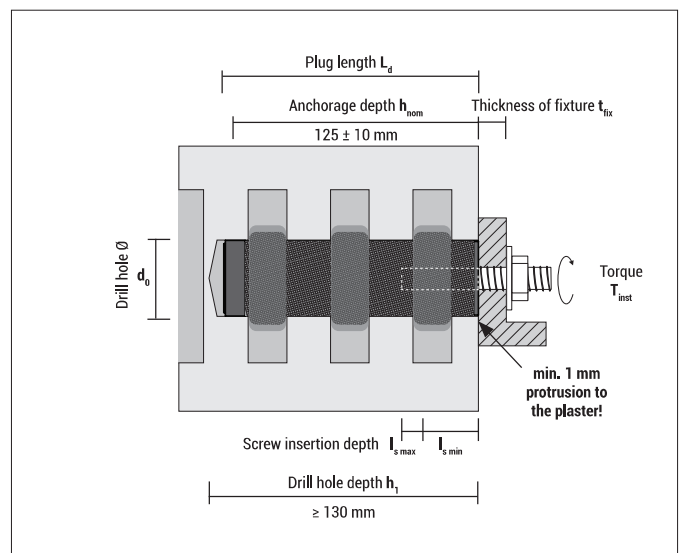

Heavy-duty sleeve ResiTHERM® S

Mounting in hollow brick

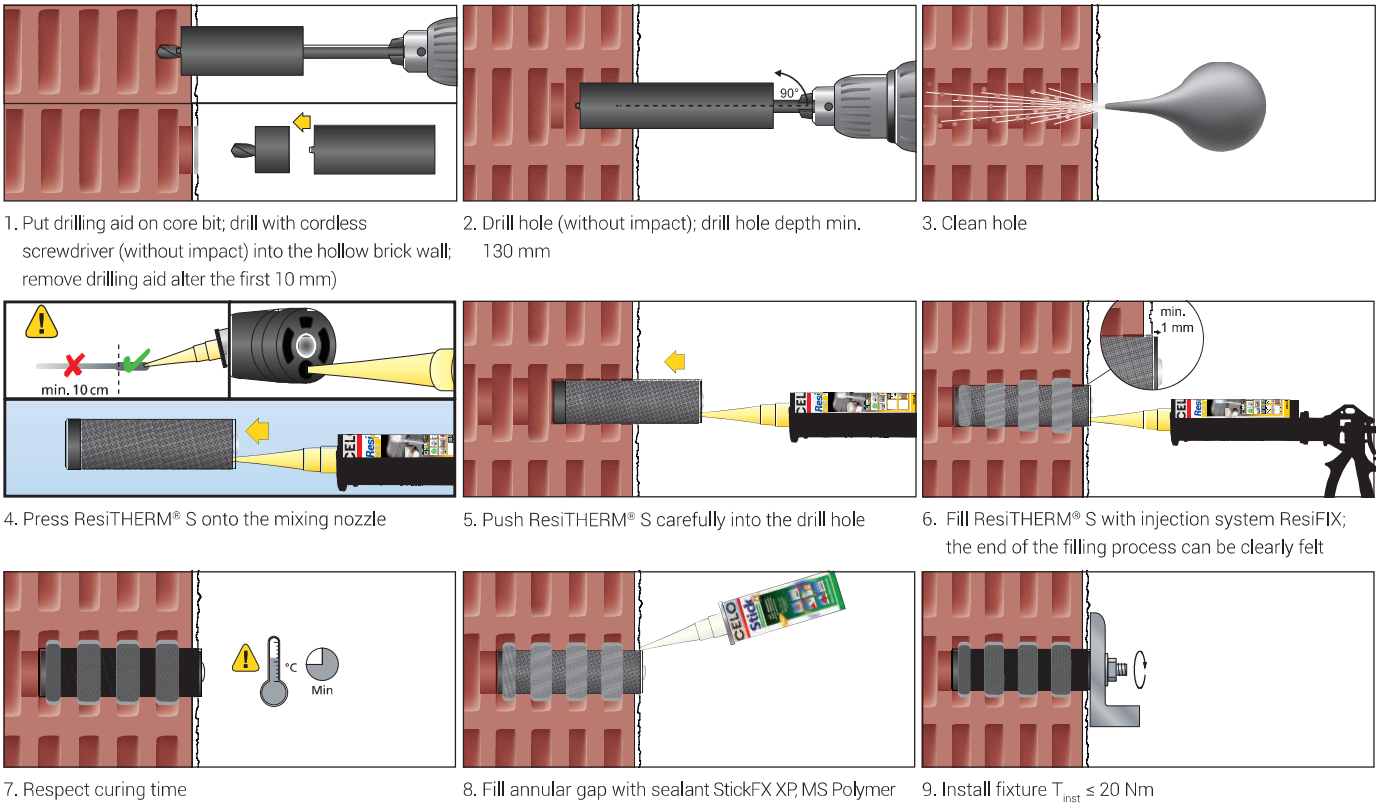

Heavy-duty sleeve ResiTHERM® S for non-insulated hollow brick walls

Type	Art-No	Set contains (packed in bag)	L_d [mm]	Thickness of insulation material t_p [mm]	€ / Set	[Set]	[Sets]
RTH S	RTHS2	2x ResiTHERM® S 2x Threaded stud M12x70 mm, stainless steel A4 2x Washer M12 DIN 125, stainless steel A4 2x Hexagon nut M12 DIN 934, stainless steel A4 1x ResiFIX VY300SF	125	0		1	10

ResiTHERM® / ResiTHERM® S Accessories

Core bit for perforated brick BST



Drilling aid for core bit ABH



Core bit BST and drilling aid ABH for core bit for ResiTHERM*

Type	Art-No	d [mm]	L [mm]	Connecting thread	€ / pc	[pcs]	[pcs]
BST 39 x 220	39220BST	39	220	M16		1	-
ABH	39ABH	35	60	-		1	-

AD 100



AD 200



Adapter shank AD hexagon for core bit BST for ResiTHERM*

Type	Art-No	L [mm]	Connecting thread	Shank for drilling machine	Insulation thickness ≤ [mm]	€ / pc	[pcs]	[pcs]
AD 100	100M16AD	100	M16	hexagon	160		1	-
AD 200*	200M16AD	200	M16	hexagon	260		1	-

* The AD 200 is required for a thickness of the insulation material > 160 mm.



Vynylester VYSF (styrene free)

Type	Art-No	Content [ml]	Mixings nozzles included [pcs]	€ / pc	[pcs]
VY 300 SF	300VSF	280	2		12

Curing times see page 156.



StickFX Professional all-purpose adhesive XP

Type	Art-No	Content [ml]	Colour	Description	€ / pc	[pcs]
XP white	BL290MSXP	290	white	All-purpose adhesive, fills gaps		12

ResiTHERM® / ResiTHERM® S Accessories



Distance washer AS Polyamid, DIN 9021 for M12

Type	Art-No	Outer Ø [mm]	Disc hole Ø [mm]	Height H [mm]	€ / 100 pcs	[pcs]	[pcs]
AS	129021AS	37	13	3		50	–

To use as a distance washer for relining (if needed).



Manual dispenser APVM

Type	Art-No	Suitable for ResiFIX Type	€ / 100 pc	[pcs]
APVM	345APVM	345 / 300 / 280 / 165		1

Manual dispenser APVM is recommended to read the scale units of ResiFIX VY (outer rod serves as a pointer).



Blow out pump AB

Type	Art-No	Tube-Ø [mm]	€ / pc	[pcs]	[pcs]
AB	BOP	8		1	–

ResiTHERM® / ResiTHERM® S technical data



Installation parameters			ResiTHERM® S	ResiTHERM® 120	ResiTHERM® 160	ResiTHERM® 200
Anchor length	L	[mm]	125	245	285	325
Thickness of insulation material	h_D	[mm]	0	60 ¹⁾ - 120	120 ¹⁾ - 160	160 ¹⁾ - 200
Anchor \varnothing	d	[mm]	37		37	
Drill hole \varnothing	d_0	[mm]	39 - 40		39 - 40	
Drill hole depth	$h_{1 \geq}$	[mm]	130		130	
Anchorage depth	h_{nom}	[mm]	125 ± 10 ²⁾		125 ± 10 ²⁾	
Connecting thread		[mm]	M12		M12	
Screw insertion depth of M12 threaded stud	$l_{s \min-max}$	[mm]	35 - 40		35 - 80	
Thickness of fixture	$t_{fix \leq}$	[mm]	22 ³⁾		22 ³⁾	
\varnothing of clearance hole in fixture	$d_{f \leq}$	[mm]	14		14	
Required volume of ResiFIX VY per ResiTHERM®		[ml]	ca. 140		ca. 140	
Installation torque for mounting the fixture	$T_{inst \leq}$	[Nm]	20		20	

¹⁾ ResiTHERM® may be cut up to 40 mm if needed. ResiTHERM® 120: If thickness of insulation material is 60 mm, set 20 mm deeper.

²⁾ Tests with a minimum anchorage depth of 115 mm showed the same pulled-out values, see test report from IFBT, Leipzig.

³⁾ When using the included threaded stud with L=70 mm. If needed a longer threaded stud or metric screw can be used.

Loads and displacements/deflections ResiTHERM®: tested system with injection system ResiFIX VY

Building material	System	Thickness of insulation material	Recommended loads ¹⁾	Displacement/deflection at recommended load*
Recommended tension load			N_{rec} [kN]	δ [mm]
Hollow brick T1.0-240	Single fastening	all	1,74	0,24
Hollow brick T10-300	Single fastening	all	1,56	0,31
Aerated concrete AAC2-0,35	Single fastening	all	1,21	0,14
Aerated concrete AAC4-0,55	Single fastening	all	2,12	0,32
Recommended pressure load			F_{rec} [kN]	δ [mm]
Hollow brick T1.0-240	Single fastening	all	4,23	0,57
Hollow brick T10-300	Single fastening	all	1,17	0,11
Recommended shear load ²⁾			V_{rec} [kN]	δ [mm]
Hollow brick T1.0-240	Single fastening	0	3,77	1,80
		120	0,97	3,90
		160	0,90	6,31
	Double fastening ³⁾	120	0,49	5,81
		160	1,27	1,61
		200	0,98	2,45
Hollow brick T10-300	Single fastening	0	0,41	1,37
		120	1,39	0,39
		160	0,97	2,50
	Double fastening ³⁾	160	0,90	7,10
		200	0,49	5,52
		120	0,52	0,54
		160	0,41	0,69
		200	0,40	2,02

¹⁾ Recommended loads include the partial safety factor on action of $\gamma_r = 1,4$.

²⁾ For interpolated values see test report from IFBT, Leipzig.

³⁾ Spacing of 77 mm (standard awning console).

* Movement of ResiTHERM® in load direction at recommended load.

Application of ResiTHERM® in solid building materials is possible. For details please contact CELO or see test report from IFBT, Leipzig

Spacing and edge distance

ResiTHERM® S, 120, 160, 200			
Minimum spacing	S_{min}	[mm]	77 ³⁾
Minimum edge distance	C_{min}	[mm]	125
Minimum thickness of structural part	h_{min}	[mm]	200

³⁾ Spacing of 77 mm (standard awning console).

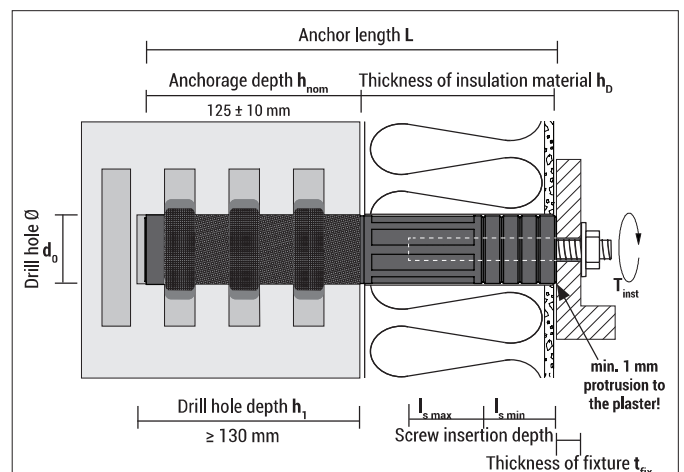

Bonded anchor VA



Advantages



Bonded anchor VA



Anchor stud VA AST

- Suitable for fastening heavy loads in concrete with small edge distances
- The VA bonded anchor utilises the joint between the steel, the mortar and the concrete
- During installation the glass tube is crushed and mixes with the resin, hardener and the aggregates
- The bonded anchor VA made of two components contains styrene free vinylester resin
- Long shelf life of min. 2.5 years
- Anchor stud VA AST: Every box includes a setting tool

Approvals and certificates



European Technical Assessment
Option 7 for non-cracked concrete

Suitable building materials

Very suitable



- Concrete



Suitable to a limited extent



- Dense natural stone
- Solid brick
- Solid sand-lime brick

Mounting

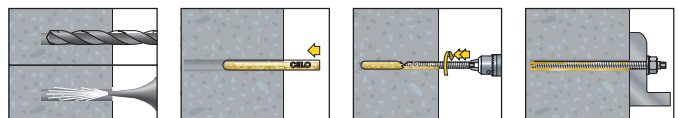

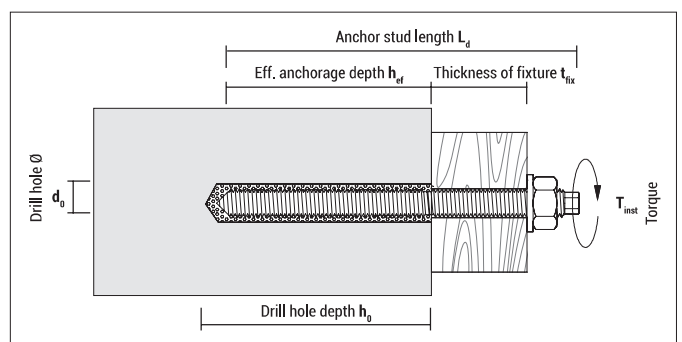

- Installation by rotation in combination with impact
- Mounting only possible with anchor rods VA AST (anchor rod must be sharpened)



Bonded anchor VA and sharpened anchor studs VA AST



VA

Type	Art-No	d ₀ [mm]	h ₀ [mm]	Suitable for VA AST		€ / 100 pcs	 [pcs]	 [pcs]
VA M8	98VA	10	80	M8	●		10	200
VA M10	910VA	12	90	M10	●		10	200
VA M12	912VA	14	110	M12	●		10	200
VA M16	916VA	18	125	M16	●		10	200
VA M20	920VA	25	170	M20	●		5	50
VA M24	924VA	28	210	M24	●		5	50
VA M30	930VAS	35	280	M30	–		5	25

Loads, spacing and edge distance in non-cracked concrete, max. temperature 50/80 °C

Type	Non-cracked concrete C20/25 ^{1) 2) 3)}						Spacing ⁵⁾		Edge distance ⁵⁾		Min. thickness of structural part h _{min} [mm]	Max. Torque T _{inst} ≤ [Nm]
	Tension load standard cleaning	Tension load premium cleaning ⁴⁾	Shear load		Bending moment		S _{cr} [mm]	S _{min} [mm]	C _{cr, N} [mm]	C _{min} [mm]		
	N _{per} [kN]	N _{per} [kN]	zinc plated V _{per} [kN]	A4 V _{per} [kN]	zinc plated M _{per} [Nm]	A4 M _{per} [Nm]						
M8	3,6	4,8	4,4	5,0	8,8	10,1	240	60	120	60	110	10
M10	4,8	6,4	7,1	7,8	16,5	18,8	270	70	135	70	120	20
M12	6,4	9,9	10,4	11,9	30,8	34,3	330	85	165	85	150	40
M16	9,9	13,9	19,8	22,4	79,1	88,8	380	95	190	95	160	60
M20	15,9	23,8	31,3	35,3	156,6	175,8	510	130	255	130	220	120
M24	23,8	29,8	45,6	50,8	273,6	306,6	630	160	315	160	300	150
M30*	60,0	–	60,0	60,0	642,0	402,0	700	280	350	140	330	400

¹⁾ Permissible loads for single anchor without influence of spacing and edge distance.

²⁾ Load figures include the resistances' partial safety factors as per ETA assessment and a partial safety factor on the action of γ_F = 1,4.

³⁾ For higher concrete strengths up to C50/60 the values increase by max. 19%.

⁴⁾ Premium cleaning: For details see ETA assessment.

⁵⁾ If underrun the char. spacing or edge distance (C_{cr} or S_{cr}) the loads must be reduced. h_{min}, S_{min} and C_{min} must be observed.

* Not part of the ETA assessment. Values according to former DIBt approval.

Curing times in dry concrete

Temperature inside drill hole	[°C]	> 0	> +5	> +10	> +20
Min. curing time	[min]	180	90	40	20

Installation possible in dry or wet concrete.

Installation for anchor sizes M12 to M24 possible in holes filled with water (no sea water) as well.

For wet concrete or drill holes filled with water curing time must be doubled.

Bonded anchor VA and sharpened anchor studs VA AST

Sharpened anchor studs **VA AST**

Approvals and certificates

**VA AST, zinc plated 5.8** with nut, washer and hex-head

Type d_s - L	Art-No	d_0 [mm]	$h_{ef} = h_0$ [mm]	L [mm]	$t_{fix} \leq$ [mm]	Nut	€ / 100 pcs	[pcs]	[pcs]
M8-110	98100AST	10	80	110	16	SW 13		10	100
M10-130	910130AST	12	90	130	22	SW 17		10	100
M10-165	910165AST	12	90	165	58	SW 17		10	100
M10-190	910190AST	12	90	190	82	SW 17		10	60
M12-160	912160AST	14	110	160	30	SW 19		10	100
M12-220	912220AST	14	110	220	90	SW 19		10	40
M12-250	912250AST	14	110	250	120	SW 19		10	40
M12-300	912300AST	14	110	300	170	SW 19		10	40
M16-165	916165AST	18	125	165	13	SW 24		10	60
M16-190	916190AST	18	125	190	38	SW 24		10	60
M16-250	916250AST	18	125	250	98	SW 24		10	40
M20-260	920260AST	25	170	260	70	SW 30		5	20
M24-300	924300AST	28	210	300	65	SW 36		5	20
M30-380*	930380AST	35	280	380	70	SW 46		5	—

* Not part of the assessment; without hexagon head

Every box contains a setting tool.

**VA AST, stainless steel A4** with nut, washer and hex-head

Type	Art-No	d_0 [mm]	$h_{ef} = h_0$ [mm]	L [mm]	$t_{fix} \leq$ [mm]	Nut	€ / 100 pcs	[pcs]	[pcs]
M8-110	9X8100AST	10	80	110	16	SW 13		10	100
M10-130	9X10130AST	12	90	130	22	SW 17		10	100
M12-160	9X12160AST	14	110	160	30	SW 19		10	100
M16-190	9X16190AST	18	125	190	38	SW 24		10	60
M20-260	9X20260VMAS	25	170	260	70	SW 30		5	20

Every box contains a setting tool.

Adhesives and Sealants

StickFX

Advantages



StickFX CL
Adhesive and sealant



StickFX XP
All-purpose



StickFX HT
Mounting adhesive

- MS Polymer - One-component adhesive and sealant with strong and quick initial adhesion
- Free of hazardous substances, odourless
- Contains no solvent, therefore especially suitable for fastening on tiles, Styrofoam, wood, and many plastics, etc.
- Can be painted over, even with water based paints
- Constant elasticity and vibration resistance once hardened
- Can be used on absorbent and non-absorbent base materials
- Surfaces can even be wet; underwater application also possible
- For indoor and outdoor use
- Colour fastness, weather resistant and UV resistant
- Temperature resistant -40°C to +90°C

Approvals and certificates



Applications

Multiple applications in the area of sanitary, heating and air conditioning, maintenance and repairs, doors and windows, construction in general, interior finishing, nautics aso.



Adhesives and Sealants StickFX Professional



StickFX Professional adhesive and sealant CL

Type	Art-No	Content [ml]	Colour	Description	€ / pc	 [pcs]
CL	TR290MSCL	290	transparent	Adhesive and sealant		12



StickFX Professional all-purpose adhesive XP

Type	Art-No	Content [ml]	Colour	Description	€ / pc	 [pcs]
XP white	BL290MSXP	290	white	All-purpose adhesive, fills gaps		12
XP grey	GR290MSXP	290	grey	All-purpose adhesive, fills gaps		12



StickFX Professional mounting adhesive HT

Type	Art-No	Content [ml]	Colour	Description	€ / pc	 [pcs]
HT	BL290MSHT	290	white	Mounting adhesive, high initial tack		12

Adhesives and Sealants StickFX Professional

Technical data at +20 °C and 65 % relative humidity

	StickFX Professional CL	StickFX Professional XP	StickFX Professional HT
Description	Crystal clear adhesive and sealant	All-purpose adhesive and sealant	Mounting adhesive and sealant
Colour	100% transparent	white, grey	white
Base	MS Polymer	MS Polymer	MS Polymer
Curing system	Moisture cure	Moisture cure	Moisture cure
Initial tack	16 kg/m ²	40 kg/m ²	ca. 200 kg/m ²
Final tack	24 kg/cm ²	18 kg/cm ²	24 kg/cm ²
Skin formation	ca. 10 minutes	ca. 10 minutes	ca. 10 minutes
Curing rate	2 - 3 mm / 24 hours	2 - 3 mm / 24 hours	2 - 3 mm / 24 hours
Processing temperature	0 °C to +35 °C	0 °C to +35 °C	0 °C to +35 °C
Temperature resistance	-40 °C to +90 °C	-40 °C to +90 °C	-40 °C to +90 °C
Specific gravity (DIN 53479)	1,04 g/ml	1,67 g/ml	1,62 g/ml
Maximum deformation (DIN EN ISO 11600)	20 %	20 %	20 %
Elongation at break (DIN 53504)	300 %	750 %	400 %
Tear strength (DIN 53504)	2,4 N/mm ²	1,8 N/mm ²	3,5 N/mm ²
Hardness (DIN 53505)	38 ± 5	40 ± 5	65 ± 5
Storage	+5 °C to +25 °C	+5 °C to +25 °C	+5 °C to +25 °C
Shelf life*	12 months	12 months	12 months

* In unopened packaging

Further Installation Instructions/Guidelines

- **The surfaces need to be clean, dust free, and fat free**
- **Outstanding adhesion on various surfaces such as** metals, plastics/synthetic materials (polystyrene, polycarbonate, PVC, polyamide, and GFK – not ABS, PP, PE, PMMA, PTFE, and silicone), Styrofoam/polystyrene, cork, concrete, glass, wood, etc.
- **Chemical resistance:**
Good resistance against water (including seawater), aliphatic solvents, diluted inorganic acids and bases, oils, and fats/greases. Low resistance against aromatic solvents, concentrated acids and chlorinated hydrocarbons.
- **Joint dimensions:**
Stick FX Professional CL: 1 - 3 mm for adhesion, 2 - 3 mm for sealing
Stick FX Professional XP: 2 - 10 mm for adhesion, 5 - 30 mm for sealing
Stick FX Professional HT: 2 - 10 mm for adhesion, 5 - 30 mm for sealing