

MEFA-Fixpoints and accessories

Pipelines will expand under temperature influence. To balance these length elongations, compensators or expansion bends will be integrated in the piping.

The compensating pipeline alignments have to be limited in their lengths, as their thrusts may cause damages on the building or on the compensator. The fixpoint limits these enlargements.

The total load of a fixpoint in connection with a compensator is independent of pressure, temperature differences and pipe lengths between the compensator and fixpoints, as well as the value balgen cross-section and axial value resistance. Pipelines fixed on building constructions have to be mounted with sound insulations according to DIN 4109.

Specification:

The body material of the fixpoint is galvanized. Raw parts e.g. the welding lug for fixpoints should also be coated after welding. We recommend to protect all raw parts and weldings by zinc-rich primer or zinc-spray.

Operation/Installation advice:

- suitable for straight, unramified pipeline alignment with axial compensator or U-expansion bend
- forced guide bearing within spitting distance of the compensator is obligatory

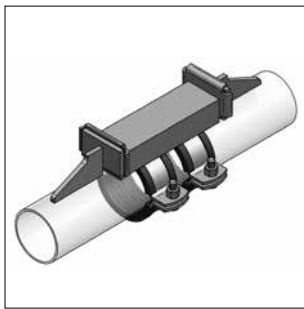

Fixpoint type A
Page 3a/2

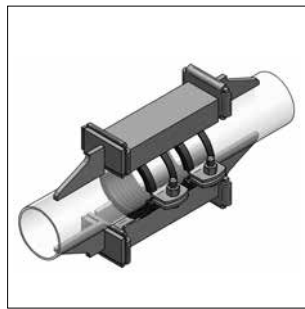

Fixpoint type B
Page 3a/3

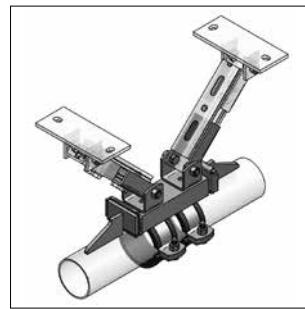

Fixpoint type A with joint holder
Page 3a/4

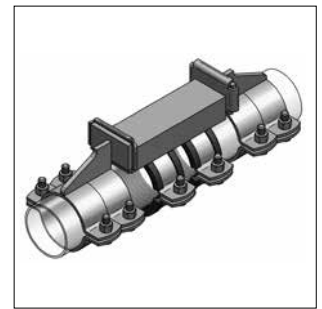

Fixpoint type A/K
Page 3a/5

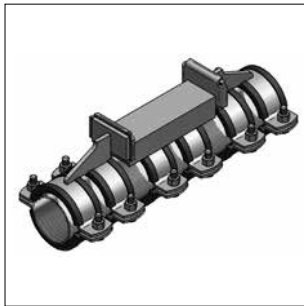

Fixpoint type A/K-MD
Page 3a/6

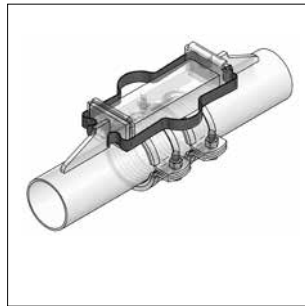

Mounting clamps for fixpoints
Page 3a/7

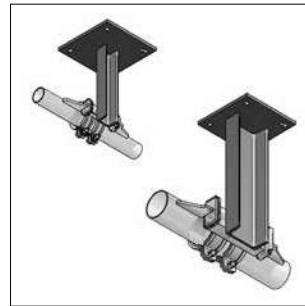

Fixpoint consoles
Page 3a/8

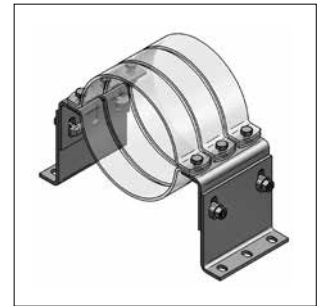

Fixpoint bracket HV
Page 3a/9

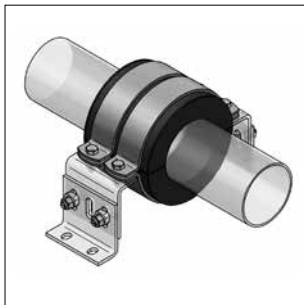

Insulated fixpoint
Page 3a/10

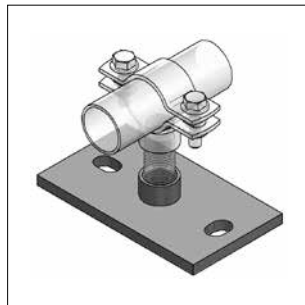

Clamping fixpoint
Page 3a/11

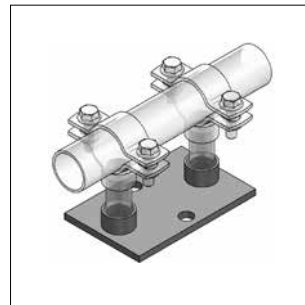

Fixpoint type FGL
Page 3a/12

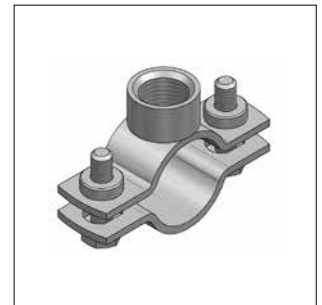

Pipe clamp FGL
Page 3a/12

i Fixpoints (welded) for stainless steel pipes see chapter 13
Remarks to fixpoints see chapter 15

3a

Fixpoint type A (for welding)

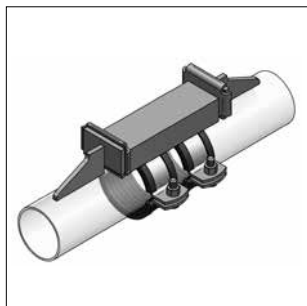

Fixpoint type A (mounted)

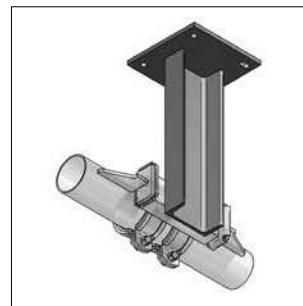
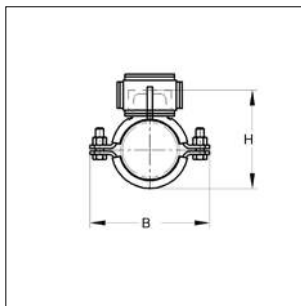
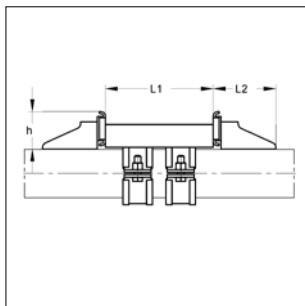

Fixpoint type A
with fixpoint console

Specification:

Application area: ferritic steel pipes
 Number of sectional steels: 1 piece
 Number of pressure pads: 2 pieces
 OD: 15 up to 160 mm
 Sectional steel: T-steel (up to Ø pipe 57,0 mm)
 U-steel (from Ø pipe 60,3 mm)
 Sound insulation: for DIN 4109

Technical data:

Material: steel
 Material type: S235JR
 Surface: galvanized

Sound insulation lining: Rubber TPE
 Temperature resistance: - 35 °C up to + 100 °C



Silicone
 - 50 °C up to + 250 °C

¹⁾ bearing pressure or reactive force depends on weld seam on site (min. 3 mm fillet weld right / left).
 The quality of weld seam has to be proofed.

Fixpoint size I, T-steel (accessory: mounting clamp 1a / Part-No. 9000310)

Clamping-range [mm]	Material pipe clamp [mm]	Sectional steel		max. axial ¹⁾							Silicone	Rubber
		L1	L2	h	H	B	reactive force	Weight	Packing	Part-No.	Part-No.	
15 - 19	25 x 3	30 x 30 x 100	81	47	60 - 64	80	8,5	0,92	1	0030171	0020171	
20 - 25	25 x 3	30 x 30 x 100	81	47	66 - 71	87	8,5	0,95	1	0030221	0020221	
26 - 30	25 x 3	30 x 30 x 100	81	47	72 - 76	92	8,5	0,98	1	0030271	0020271	
31 - 36	25 x 3	30 x 30 x 100	81	47	77 - 82	98	8,5	1,00	1	0030341	0020341	
38 - 45	25 x 3	30 x 30 x 100	81	47	84 - 91	107	8,5	1,04	1	0030421	0020421	
47 - 51	25 x 3	30 x 30 x 100	81	47	93 - 97	114	8,5	1,08	1	0030481	0020481	
53 - 57	25 x 3	30 x 30 x 100	81	47	99 - 103	120	8,5	1,11	1	0030571	0020571	

Fixpoint size II, U-steel (accessory: mounting clamp 2 / Part-No. 9000312)

Clamping-range [mm]	Material pipe clamp [mm]	Sectional steel		max. axial ¹⁾							Silicone	Rubber
		L1	L2	h	H	B	reactive force	Weight	Packing	Part-No.	Part-No.	
60,3	50 x 5	65 x 42 x 200	116	69	112,5	148	20	4,51	1	0030601	0020601	
76,1	50 x 5	65 x 42 x 200	116	69	131,0	166	20	4,75	1	0030761	0020761	
88,9	50 x 5	65 x 42 x 200	116	69	146,0	179	20	4,95	1	0030891	0020891	
108,0	50 x 5	65 x 42 x 200	116	69	165,0	199	20	5,23	1	0031081	0021081	
114,3	50 x 5	65 x 42 x 200	116	69	171,5	205	20	5,32	1	0031141	0021141	
133,0	50 x 5	80 x 45 x 200	116	69	191,0	224	20	5,98	1	0031331	0021331	
139,7	50 x 5	80 x 45 x 200	116	69	198,5	231	20	6,78	1	0031401	0021401	
159 - 160	50 x 5	80 x 45 x 200	116	69	218 - 219	251	20	6,37	1	0031591	0021591	

i mounting clamps for fixing pressure pads have to be ordered separately (see page 3a/7)

⚠ mounting recommendation see chapter 15

Fixpoint type B (for welding)

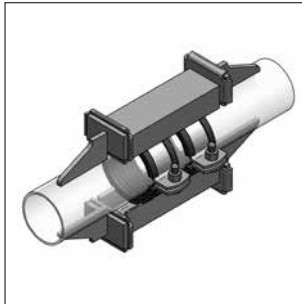

Fixpoint type B (mounted)

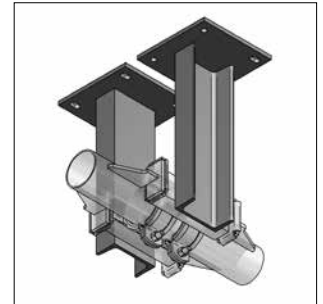
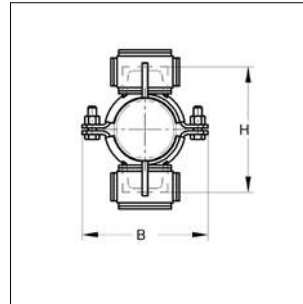
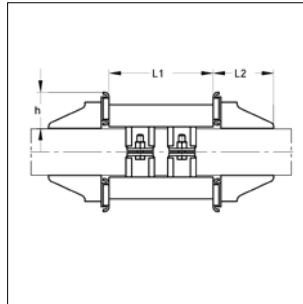

Fixpoint type B
with two fixpoint consoles

3a

Specification:

Application area: ferritic steel pipes
 Number of sectional steels: 2 pieces
 Number of Pressure pads: 4 pieces
 OD: 20 up to 356 mm
 Sectional steel: T-steel (up to Ø pipe 57,0 mm)
 U-steel (from Ø pipe 60,3 mm)
 Sound insulation: according to DIN 4109

Technical data:

Material: steel
 Material type: S235JR
 Surface: galvanized
 Sound insulation lining: Rubber TPE
 Temperature resistance: - 35 °C up to + 100 °C



Silicone
 - 50 °C up to + 250 °C

¹⁾ bearing pressure or reactive force depends on weld seam on site (min. 3 mm fillet weld right / left).
 The quality of weld seam has to be proofed.

Fixpoint size I, T-steel (accessory: mounting clamp 1a /Part-No. 9000310)

Clamping-range [mm]	Material pipe-clamp [mm]	Sectional steel							max. axial ¹⁾ reactive force [kN]	Weight [kg/pc.]	Packing [pc.]	Silicone	Rubber
		Part-No.	Part-No.										
			L1	L2	h	H	B						
			[mm]	[mm]	[mm]	[mm]	[mm]	[mm]					
20 - 25	25 x 3	30 x 30 x 100	81	47	96 - 101	87	17	1,54	1	0030222	0020222		
26 - 30	25 x 3	30 x 30 x 100	81	47	102 - 106	92	17	1,57	1	0030272	0020272		
31 - 36	25 x 3	30 x 30 x 100	81	47	107 - 112	98	17	1,59	1	0030342	0020342		
38 - 45	25 x 3	30 x 30 x 100	81	47	114 - 121	107	17	1,62	1	0030422	0020422		
47 - 51	25 x 3	30 x 30 x 100	81	47	123 - 127	114	17	1,67	1	0030482	0020482		
53 - 57	25 x 3	30 x 30 x 100	81	47	129 - 133	120	17	1,70	1	0030572	0020572		

Fixpoint size II, U-steel (accessory: mounting clamp 2 /Part-No. 9000312)

Clamping-range [mm]	Material pipe-clamp [mm]	Sectional steel							max. axial ¹⁾ reactive force [kN]	Weight [kg/pc.]	Packing [pc.]	Silicone	Rubber
		Part-No.	Part-No.										
			L1	L2	h	H	B						
			[mm]	[mm]	[mm]	[mm]	[mm]	[mm]					
60,3	50 x 5	65 x 42 x 200	116	69	143	148	40	7,29	1	0030602	0020602		
76,1	50 x 5	65 x 42 x 200	116	69	164	166	40	7,54	1	0030762	0020762		
88,9	50 x 5	65 x 42 x 200	116	69	180	179	40	7,73	1	0030892	0020892		
108,0	50 x 5	65 x 42 x 200	116	69	200	199	40	8,02	1	0031082	0021082		
114,3	50 x 5	65 x 42 x 200	116	69	207	205	40	8,11	1	0031142	0021142		
133,0	50 x 5	80 x 45 x 200	116	69	227	224	40	9,13	1	0031332	0021332		
139,7	50 x 5	80 x 45 x 200	116	69	235	231	40	9,23	1	0031402	0021402		
159 - 160	50 x 5	80 x 45 x 200	116	69	256 - 257	251	40	9,52	1	0031592	0021592		

Fixpoint size III, U-steel

Clamping-range [mm]	Material pipe-clamp [mm]	Sectional steel							max. axial ¹⁾ reactive force [kN]	Weight [kg/pc.]	Packing [pc.]	Silicone	Rubber
		Part-No.	Part-No.										
			L1	L2	h	H	B						
			[mm]	[mm]	[mm]	[mm]	[mm]	[mm]					
168,3	50 x 5	120 x 55 x 330	116	70	263	258	60	16,94	1	0031682	0021682		
193,7	50 x 5	120 x 55 x 330	116	71	294	284	60	17,33	1	0031942	0021942		
219,0	50 x 5	120 x 55 x 330	116	72	322	309	60	17,70	1	0032192	0022192		
273 - 274	50 x 5	120 x 55 x 330	116	73	382 - 383	363	60	18,51	1	0032732	0022732		
323,9	50 x 5	120 x 55 x 330	116	74	437	414	60	19,28	1	0033242	0023242		
355 - 356	50 x 5	120 x 55 x 330	116	75	469 - 470	446	60	19,76	1	0033562	0023562		

i mounting clamps for fixing pressure pads have to be ordered separately (see page 3a/7)

⚠ mounting recommendation see chapter 15

Fixpoint type A with joint holder (for welding)

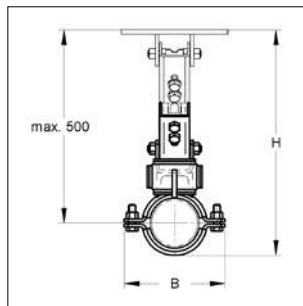
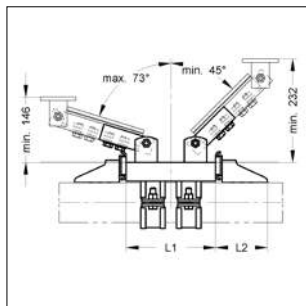

3a

Fixpoint type A with joint holder (mounted)

Specification:

Application area: ferritic steel pipes
 Number of sectional steels: 1 piece
 Number of pressure pads: 2 pieces
 OD: 20 up to 160 mm
 Sectional steel: T-steel (up to Ø pipe 57,0 mm)
 U-steel (from Ø pipe 60,3 mm)
 Sound insulation: according to DIN 4109

Technical data:

Material: steel
 Material type: S235JR
 Surface: galvanized
 Sound insulation lining: Rubber TPE
 Temperature resistance: - 35 °C up to + 100 °C

Needed accessory:

2 x joint holder with plate
 2 x profile rail 45/45/2,5 (length on request)
 8 x hexagon screw M12 x 25
 4 x 2-hole tooth plate M12
 8 x washer
 2 x mounting clamp 1b or 2

Delivery time:

5 working days, ex works

¹⁾ bearing pressure or reactive force depends on weld seam on site (min. 3 mm fillet weld right / left), also on the angle, the length and type of selected profile rail.
 The quality of weld seam has to be proofed.

Fixpoint size I, T-steel (accessory: mounting clamp 1b /Part-No. 9000311) Rubber

Clamping-range [mm]	Material pipe clamp [mm]	Sectional steel				H _{max.} [mm]	H _{min.} [mm]	B [mm]	max. axial ¹⁾ reactive force [kN]	Weight [kg/pc.]	Packing [pc.]	Rubber Part-No.
		L1 [mm]	L2 [mm]	L1 [mm]	L2 [mm]							
20 - 25	25 x 3	30 x 30 x 140	81	521	186	87	8,5	2,66	1	9999671		
26 - 30	25 x 3	30 x 30 x 140	81	523	192	92	8,5	2,69	1	9999932		
31 - 36	25 x 3	30 x 30 x 140	81	526	197	98	8,5	2,71	1	9999835		
38 - 45	25 x 3	30 x 30 x 140	81	531	204	107	8,5	2,75	1	9999868		
47 - 51	25 x 3	30 x 30 x 140	81	534	213	114	8,5	2,79	1	9999869		
53 - 57	25 x 3	30 x 30 x 140	81	537	219	120	8,5	2,82	1	9999864		

Fixpoint size II, U-steel (accessory: mounting clamp 2 /Part-No. 9000312) Rubber

Clamping-range	Material pipe clamp	Sectional steel	H _{max.}	H _{min.}	B	max. axial ¹⁾ reactive force	Weight	Packing	Rubber Part-No.
60,3	50 x 5	65 x 42 x 200	541	232,5	149	15	6,15	1	9999672
76,1	50 x 5	65 x 42 x 200	549	251,5	166	15	6,39	1	9999933
88,9	50 x 5	65 x 42 x 200	556	266	179	15	6,58	1	9999865
108,0	50 x 5	65 x 42 x 200	565	285	199	15	6,87	1	9999866
114,3	50 x 5	65 x 42 x 200	568	291,5	205	15	6,96	1	9999773
133,0	50 x 5	80 x 45 x 200	578	311	224	15	7,61	1	9999772
139,7	50 x 5	80 x 45 x 200	581	318,5	231	15	7,72	1	9999673
159 - 160	50 x 5	80 x 45 x 200	591	339	251	15	8,00	1	9999674

mounting clamps for fixing pressure pads have to be ordered separately (see page 3a/7)

mounting recommendation see chapter 15

Fixpoint type A/K (for clamping)

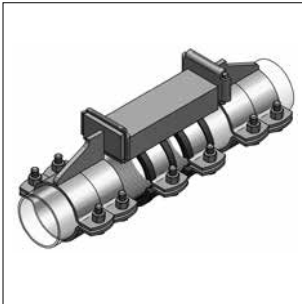

Fixpoint type A/K (mounted)

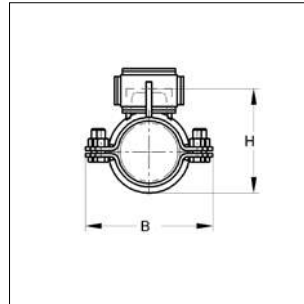
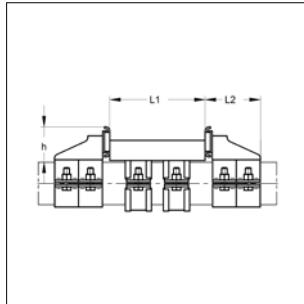

3a

Specification:

Application area: galvanized steel pipes,
ferritic steel pipes
Number of sectional steels: 1 piece
OD: 15 up to 160 mm
Sectional steel: T-steel (up to Ø pipe 57,0 mm)
U-steel (from Ø pipe 60,3 mm)
Sound insulation: according to DIN 4109

Technical data:

Material: steel
Material type: S235JR
Surface: galvanized
Sound insulation lining: Rubber TPE
Temperature resistance: - 35 °C up to + 100 °C

Remark: Change of pipe diameter due to thermal loads. In this case, sleeves has to be fixed in front of and behind the fixpoint.

Fixpoint size I, T-steel													Rubber	
Clamping-range [mm]	Material pipe clamp [mm]	Sectional steel			L1 [mm]	L2 [mm]	h [mm]	H [mm]	B [mm]	tightening torque [Nm]	max. axial reactive force [kN]	Weight [kg/pc.]	Packing [pc.]	Part-No.
15,0	25 x 3	30 x 30 x 100			81	50	61,0	80	6	8,50	1,44	1	0020153	
17,2	25 x 3	30 x 30 x 100			81	50	63,2	80	6	8,50	1,48	1	0020173	
20,0	25 x 3	30 x 30 x 100			81	50	66,0	87	6	8,50	1,52	1	0020203	
21,3	25 x 3	30 x 30 x 100			81	50	67,3	87	6	8,50	1,52	1	0020223	
22 - 23	25 x 3	30 x 30 x 100			81	50	68 - 69	87	6	8,50	1,52	1	0020233	
26 - 28	25 x 3	30 x 30 x 100			81	50	72 - 74	92	6	8,50	1,59	1	0020273	
30,0	25 x 3	30 x 30 x 100			81	50	76,0	92	6	8,50	1,63	1	0020303	
32 - 35	25 x 3	30 x 30 x 100			81	50	78 - 81	98	6	8,50	1,65	1	0020343	
38 - 40	25 x 3	30 x 30 x 100			81	50	84 - 86	107	6	8,50	1,73	1	0020403	
41 - 45	25 x 3	30 x 30 x 100			81	50	87 - 91	107	6	8,50	1,76	1	0020423	
48 - 51	25 x 3	30 x 30 x 100			81	50	94 - 97	114	6	8,50	1,86	1	0020483	
53 - 55	25 x 3	30 x 30 x 100			81	50	99 - 101	120	6	8,50	1,89	1	0020543	
58 - 60	25 x 3	30 x 30 x 100			81	50	106 - 108	129	6	8,50	1,98	1	0020583	

Fixpoint size II, U-steel													Rubber	
Clamping-range [mm]	Material pipe clamp [mm]	Sectional steel			L1 [mm]	L2 [mm]	h [mm]	H [mm]	B [mm]	tightening torque [Nm]	max. axial reactive force [kN]	Weight [kg/pc.]	Packing [pc.]	Part-No.
60,3	50 x 5	65 x 42 x 200			127	70	112,5	148	60	20,0	7,37	1	0020603	
63,0	50 x 5	65 x 42 x 200			127	70	116	151	60	20,0	7,49	1	0020630	
64,0	50 x 5	65 x 42 x 200			127	70	117	152	60	20,0	7,54	1	0020633	
70,0	50 x 5	65 x 42 x 200			127	70	124	158	60	20,0	7,78	1	0020703	
75,0	50 x 5	65 x 42 x 200			127	70	129,5	163	60	20,0	7,98	1	0020753	
76,1	50 x 5	65 x 42 x 200			127	70	131,5	166	60	20,0	8,02	1	0020763	
88,9	50 x 5	65 x 42 x 200			127	70	146	179	60	20,0	8,55	1	0020893	
108,0	50 x 5	65 x 42 x 200			127	70	165	198	60	20,0	9,32	1	0021083	
110,0	50 x 5	65 x 42 x 200			127	70	167	200	60	20,0	9,39	1	0021103	
114,3	50 x 5	65 x 42 x 200			127	70	171,5	204	60	20,0	9,56	1	0021143	
125,0	50 x 5	80 x 45 x 200			127	70	182,5	215	60	20,0	10,37	1	0021253	
133,0	50 x 5	80 x 45 x 200			127	70	191	223	60	20,0	10,70	1	0021333	
135,0	50 x 5	80 x 45 x 200			127	70	193	225	60	20,0	10,77	1	0021353	
139,7	50 x 5	80 x 45 x 200			127	70	198,5	230	60	20,0	10,98	1	0021403	
159 - 160	50 x 5	80 x 45 x 200			127	70	219 - 220	250	60	20,0	11,76	1	0021603	

Fixpoint type A/K-MD (for clamping)

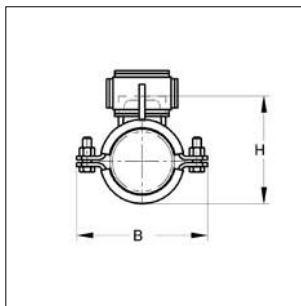
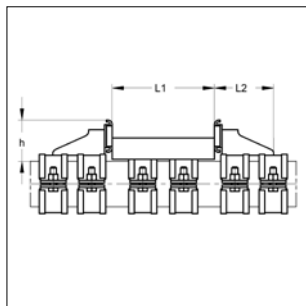
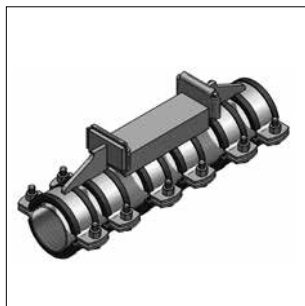

Fixpoint type A/K-MD (mounted)

Specification:

Application area: plastic pipes, copper pipes
stainless steel pipes

Number of sectional steels: 1 piece

OD: 15 up to 160 mm

Sectional steel: T-steel (up to Ø pipe 57,0 mm)
U-steel (from Ø pipe 60,3 mm)

Sound insulation: according to DIN 4109

Technical data:

Material: steel

Material type: S235JR

Surface: galvanized

Sound insulation lining: Rubber TPE

Temperature resistance: - 35 °C up to + 100 °C

Remark: Change of pipe diameter due to thermal loads. In this case, sleeves has to be fixed in front of and behind the fixpoint.

Fixpoint size I, T-steel

Clamping-range [mm]	Material pipe clamp [mm]	Sectional steel			h [mm]	H [mm]	B [mm]	tightening torque [Nm]	max. axial reactive force [kN]	Weight [kg/pc.]	Packing [pc.]	Rubber	
		[mm]	[mm]	[mm]								Part-No.	
15 - 19	25 x 3	30	30	100	81	56	61 - 65	80	6	2,00	1,58	1	0020155
20 - 25	25 x 3	30	30	100	81	56	66 - 71	87	6	2,00	1,66	1	0020215
26 - 30	25 x 3	30	30	100	81	56	72 - 76	92	6	2,00	1,75	1	0020265
31 - 36	25 x 3	30	30	100	81	56	77 - 82	98	6	2,00	1,82	1	0020315
38 - 45	25 x 3	30	30	100	81	56	84 - 91	107	6	4,00	1,92	1	0020385
47 - 51	25 x 3	30	30	100	81	56	93 - 97	114	6	4,00	2,05	1	0020475
53 - 57	25 x 3	30	30	100	81	56	99 - 103	120	6	4,00	2,14	1	0020535

Fixpoint size II, U-steel

Clamping-range [mm]	Material pipe clamp [mm]	Sectional steel			h [mm]	H [mm]	B [mm]	tightening torque [Nm]	max. axial reactive force [kN]	Weight [kg/pc.]	Packing [pc.]	Rubber	
		[mm]	[mm]	[mm]								Part-No.	
60,3	50 x 5	65	42	200	116	80	112,5	149	60	8,50	7,96	1	0020605
63,0	50 x 5	65	42	200	116	80	116,0	152	60	8,50	8,10	1	0020635
64,0	50 x 5	65	42	200	116	80	117,0	153	60	8,50	8,14	1	0020645
70,0	50 x 5	65	42	200	116	80	124,0	160	60	8,50	8,41	1	0020705
75,0	50 x 5	65	42	200	116	80	129,5	165	60	8,50	8,64	1	0020755
76,1	50 x 5	65	42	200	116	80	131,5	166	60	8,50	8,68	1	0020765
88,9	50 x 5	65	42	200	116	80	146,0	179	60	8,50	9,27	1	0020895
108,0	50 x 5	65	42	200	116	80	165,0	199	60	8,50	10,12	1	0021085
110,0	50 x 5	65	42	200	116	80	167,0	201	60	8,50	10,21	1	0021105
114,3	50 x 5	65	42	200	116	80	171,5	205	60	8,50	10,39	1	0021155
125,0	50 x 5	80	45	200	116	80	182,5	212	60	8,50	11,26	1	0021255
133,0	50 x 5	80	45	200	116	80	191,0	224	60	8,50	11,62	1	0021335
135,0	50 x 5	80	45	200	116	80	193,0	226	60	8,50	11,71	1	0021355
139,7	50 x 5	80	45	200	116	80	198,5	231	60	8,50	11,93	1	0021405
160,0	50 x 5	80	45	200	116	80	219,5	251	60	8,50	12,82	1	0021605

■ Mounting clamps for fixpoints

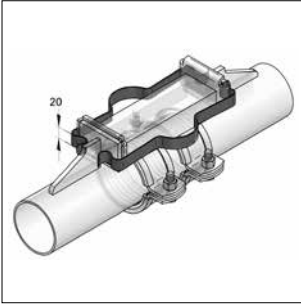

Mounting clamps for fixpoints

3a

Specification:

Required quantity: 2 pieces
Suitable for: fixpoint type A and B

Technical data:

Material: steel
Material type: S235JR
Surface: galvanized

Remark: clamps are re-usable

Description	suitable for OD [mm]	suitable for fixpoint type	Weight [kg/pc.]	Packing [pcs.]	Part-No.
Mounting clamp size 1a	21,3 - 57,0	Type A, Type B	0,060	2	9000310
Mounting clamp size 1b	21,3 - 57,0	Type A with joint holder	0,070	2	9000311
Mounting clamp size 2	60,3 - 159,0	Type A, Type B, Type A with joint holder	0,086	2	9000312

Fixpoint consoles

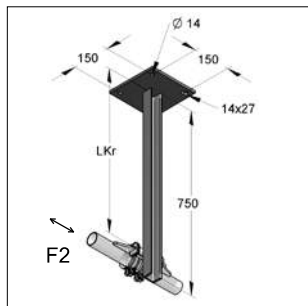

Fixpoint console 50/38/750

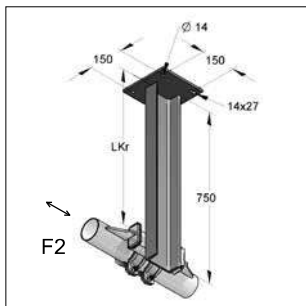

Fixpoint console 120/55/750

Technical data: Fixpoint console 50/38/750

Material: steel
 Material type: S235JR
 Surface: raw
 U-steel: overleaf welded on anchor plate,

Suitable for: fixpoint type A and B
 Mounting recommendation: foundation concrete \geq C20/25
 Delivery time: 5 working days, ex works

global safety coefficient γ : 1,35
 maximum torque: M_G : 1617,53 Nm
 Reaction force F_{AX} : 10,78 kN
 Reaction force F_{BX} : 10,78 kN
 M_G, F_{AX}, F_{BX} valid for LF2: up to L= 600 mm

Technical data: Fixpoint console 120/55/750

Material: steel
 Material type: S235JR
 Surface: raw
 U-steel: overleaf welded on anchor plate,

Suitable for: fixpoint type A and B
 Mounting recommendation: foundation concrete \geq C20/25
 Delivery time: 5 working days, ex works

global safety coefficient γ : 1,35
 maximum torque: M_G : 3504,20 Nm
 Reaction force F_{AX} : 23,36 kN
 Reaction force F_{BX} : 23,36 kN
 M_G, F_{AX}, F_{BX} valid for LF2: up to L= 1000 mm

* Fixpoint consoles in galvanized on request

Fixpoint console 50/38/750

Description	Length [mm]	Length LKr [mm]	max.load		Anchor plate [mm]	Weight [kg/pc.]	Packing [pc.]	Part-No.
			Load situation 2	F2 [kN]				
Fixpoint console 50/38 raw	750	100	16,18		200 x 200 x 10	7,40	1	9997799
		200	8,09					
		300	5,39					
		400	4,04					
		500	3,24					
		600	2,70					
		700	2,27					

Fixpoint console 120/55/750

Fixpoint console 120/55 raw	750	100	35,04		200 x 200 x 10	13,60	1	9996491
		200	17,50					
		300	11,68					
		400	8,76					
		500	7,00					
		600	5,84					
		700	5,00					

Fixpoint bracket HV

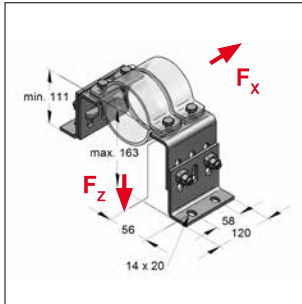

Fixpoint bracket HV1

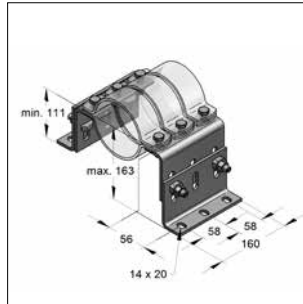

Fixpoint bracket HV2

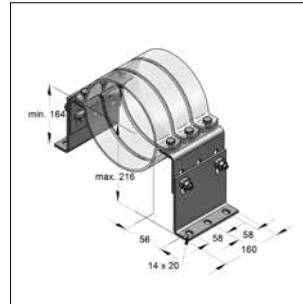

Fixpoint bracket HV3

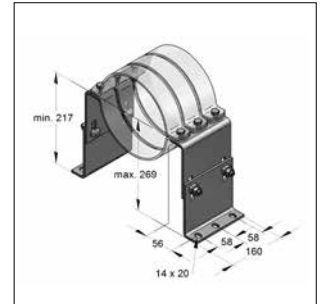

Fixpoint bracket HV4

3a

Specification:

Application area: Height adjustable bracket for fixation of pipes without sound insulation. To use as fixpoint in conjunction with MEFA Titan HD clamps. Also applicable as height adjustable substructure of rail constructions.

Remark: High-strength bolting through CENTUM-T-lock head connection can be fixed on any substructure (C-profile rail, CENTUM, steel girder)

Scope of delivery: 2 x angle (stilt)
2 x angle (side part)
4 x T-lock head M12x40
4 or 6 x hexagon screw M12x40 + nut M12

Technical data:

Material: steel
Material type: S235JR
Surface: hot-dip galvanized
- angle: zinc-nickel
- screw joint:

Tightening torque
- pipe clamp: 60 Nm
- T-lock head: 120 Nm

(* OD < 168 mm = 18 kN, OD > 168 mm = 40 kN (limited by T-lock head connection))

Type	Length L [mm]	Axis height min.-max. [mm]	Number of fixpoint clamps [pcs.]	Reco- mmended pipe OD [mm]	Angle		max. load		Weight [kg/pc.]	Packing [pc.]	Part-No.
					stilt [pair]	side part [pair]	F_x [kN]	F_z [kN]			
HV1	120	111-163	2	64-273	120/6/100	120/6/100	20	12	3,58	1	00200405/fvz
HV2	160	111-163	3	64-273	160/6/100	160/6/100	30	18/40*	4,74	1	00200406/fvz
HV3	160	164-216	3	64-406	160/6/153	160/6/100	30	18/40*	5,69	1	00200407/fvz
HV4	160	217-269	3	64-508	160/6/153	160/6/153	30	18/40*	6,52	1	00200408/fvz

i Suitable Titan HD clamps without connection thread see on chapter 1 (also available in hot-dip galvanized coating)

X mounting recommendation see chapter 15

Insulated fixpoint

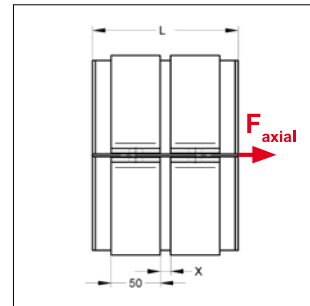
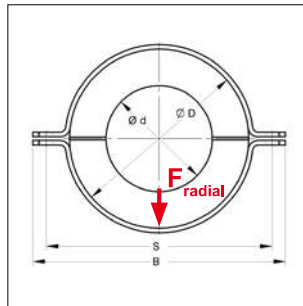
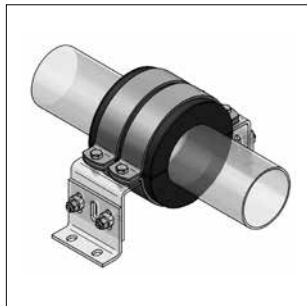

Insulated fixpoint

Specification:

Application area: Insulated fixpoint mounting of chilled water pipes of steel

Characteristic: Can be mounted to any substructures (C-profile rails, CENTUM®, steel girder). Height adjustable in combination with Fixpoint brackets HV. High water vapor diffusion resistance and low thermal conductivity. Acc. AGI the requirements

Scope of delivery: 2 x half shell with slot for inner and outer split ring
2 x inner split ring for welding to steel pipe
4 x outer split ring for fixation on substructure

Delivery time: approx. 15 working days, ex works

Technical data:

Insulating material: PUR (with natural rubber on front ends)

Density: 200 kg/m³

Thermal conductivity: 0,037 W/mK

Temperature range: -50 °C up to +105 °C

Inner / outer split ring Material: steel

Surface: raw / galvanized

***Required accessory:** Fixpoint bracket HV

OD [mm]	Insulation thickness [mm]	Recom. fixpoint bracket* [type]	Length of shell L [mm]	Dimension			Max. load		Weight [kg/pc.]	Packing [pc.]	Part-No.
				B [mm]	S [mm]	F_{axial} [kN]	F_{radial} [kN]				
76,1	40	HV1	148	235	206	2,7	5,4	3,76	1	698400076	
88,9	40	HV1	148	246	217	2,8	6,3	4,03	1	698400089	
114,3	40	HV1	148	272	243	3,3	8,0	4,66	1	698400114	
139,7	40	HV1	148	300	271	4,5	9,2	5,58	1	698400140	
168,3	40	HV1	148	328	299	5,6	10,4	6,30	1	698400168	
219,1	40	HV3	204	378	349	8,0	12,4	8,27	1	698400219	
273,0	40	HV3	204	433	404	8,9	13,6	9,85	1	698400273	
323,9	40	HV4	204	484	455	11,1	16,8	11,31	1	698400324	
355,6	40	HV4	204	516	487	12,1	18,2	12,22	1	698400356	
406,4	40	HV4	204	567	538	13,6	20,3	13,68	1	698400406	

Suitable Fixpoint brackets as substructure see page 3a/9

mounting recommendation see chapter 15

Clamping fixpoint

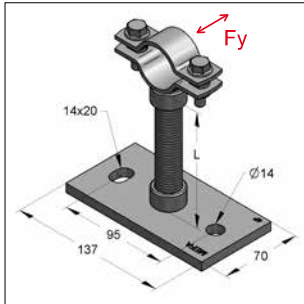

Clamping fixpoint

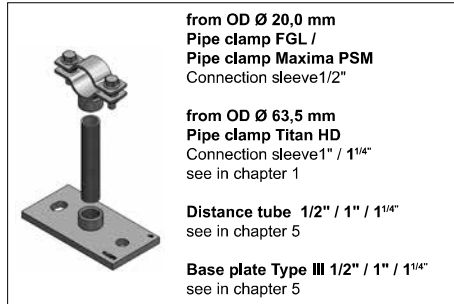

Elements of the clamping fixpoint

max. load* Fy			
Distance L	1/2"	1"	1 1/4"
[mm]	Fy [kN]	Fy [kN]	Fy [kN]
50	1,482	5,350	10,362
100	0,741	2,675	5,181
150	0,494	1,783	3,454
200	0,371	1,337	2,591
250	0,290	1,070	2,072
300	0,201	0,892	1,727
350	0,148	0,764	1,480
400	0,113	0,665	1,295
450	0,089	0,525	1,151
500	0,072	0,425	1,036

* at $\sigma_{max} = 160 \text{ N/mm}^2$, max. bending $f = L/150$

Specification:

Application area: ferritic steel pipes, plastic pipes
 Mounting: screw fastening
 OD: 20 up to 114 mm

Technical data:

Material: steel
 Material type: S235JR
 Surface: galvanized

Specification with sound-decoupling set :

Sound insulation: according to DIN 4109

Sound insulation lining: EPDM lining
 Temperature resistance: - 35 °C up to + 100 °C

Remark: use only distance tubes with straight thread

Recommended axial load of pipe clamp type:

Description	tightening torque [Nm]	max. load [kN]
Pipe clamp Maxima PSM unlined 1/2"	5	0,7
Pipe clamp Titan HD unlined 1" or 1 1/4"	60	5,0

i Admissible load based on lowest value of load table and max. recommend load of pipe clamp. To prevent from contact corrosion of Cu- and stainless steel pipes, pipe clamps with KTL-coating (for indoor application only) are available on demand.

Sound-decoupling set K

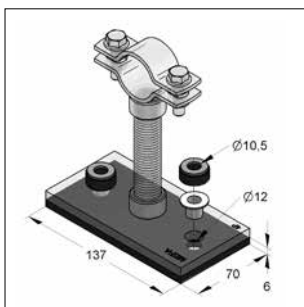

Sound-decoupling set for the clamped fixpoint

Specification:

Sound insulation: according to DIN 4109
 Washers with integrated insulation ring

Technical data:

Material
 Sound insulation lining: EPDM lining
 Temperature resistance: - 35 °C up to + 100 °C

Notice: suitable for Base plate type III as well as Holder 45 horizontal and vertical.

Description	Insulating board [mm]	Thickness insulating board [mm]	Insulating sleeve for bolting M10	Weight [kg/pc.]	Packing [pc.]	Part-No. 077034001
Sound-decoupling set K	137 x 70	6	M10	0,086	1	077034001

Fixpoint type FGL (for clamping)

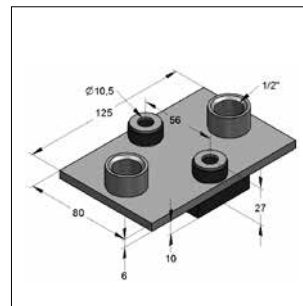
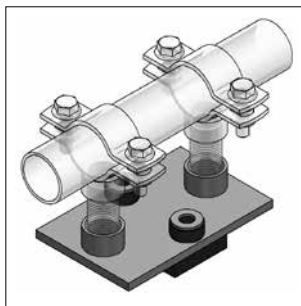
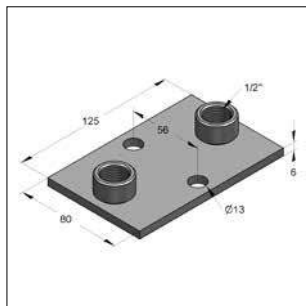
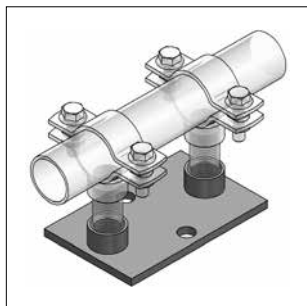

Fixpoint type FGL
(mounted with
2 double nipples 1/2")

Fixpoint type FGL, lined
(mounted with
2 double nipples 1/2")

Specification:

Application area: ferritic steel pipes,
plastic pipes
Mounting: screw fastening
OD: 20 up to 46 mm

Technical data:

Material: steel
Material type: S235JR
Surface: galvanized

Specification with sound-decoupling set:

Sound insulation: according to DIN 4109

Sound insulation lining: EPDM lining
Temperature resistance: - 35 °C up to + 100 °C

Required accessory:

2 x pipe clamp FGL
2 x double nipple 1/2"
distance tube, max. length 100 mm

Description	Connection	axial pressure absorption [kN]	Weight [kg/pc.]	Packing [pc.]	Part-No.
Fixpoint FGL	2 x sleeve 1/2"	1,4	0,531	1	0770335
Fixpoint FGL, lined	2 x sleeve 1/2"	1,4	0,588	1	9997700

Pipe clamp FGL

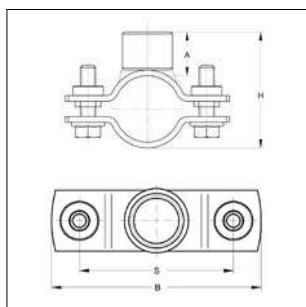
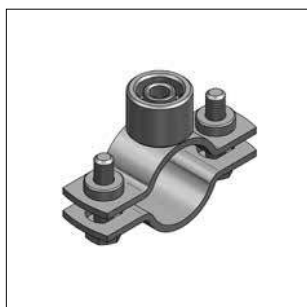

Pipe clamp FGL 3G
(with pendulum stick nut)

Specification:

Closing: pendulum stick nut
Model: 2-part
OD: 20 up to 46 mm
Connection: combination M8/M10 + 1/2"

Technical data:

Material: steel
Material type: DD11
Surface: galvanized

Clamping range [mm]	Material [mm]	Closure screws	tightening torque [Nm]	max. axial load [kN]	H [mm]	A [mm]	B [mm]	S [mm]	Weight [kg/pc.]	Packing [pc.]	Part-No.
20 - 23	25 x 3,0	M8	5	0,7	41-44	18	73	49	0,216	1	0069047
25 - 29	25 x 3,0	M8	5	0,7	46-50	18	80	56	0,225	1	0069049
30 - 35	25 x 3,0	M8	5	0,7	51-56	18	87	63	0,235	1	0069053
36 - 40	25 x 3,0	M8	5	0,7	57-61	18	92	68	0,246	1	0069081
41 - 46	25 x 3,0	M8	5	0,7	62-67	18	98	74	0,298	1	0069097